

# BrewEasy™ G2

## Adapter Lid Kit

### Assembly, Operation, & Maintenance

Congratulations on your purchase, and thank you for selecting the BrewEasy™ Adapter Lid Kit from Blichmann Engineering. We are confident that it will provide you years of service and many gallons of outstanding beer. This manual will familiarize you with the use, assembly, and the sanitation procedures for the product.

**PLEASE READ AND THOROUGHLY UNDERSTAND THIS MANUAL PRIOR TO USE FOR IMPORTANT SAFETY INFORMATION!**

### About This Manual:

**Warning:** Sections labeled "Warning" can lead to serious injury or death if not followed. Please thoroughly read these sections and understand them completely before use. If you do not understand them or have any questions, contact your retailer or Blichmann Engineering ([www.BlichmannEngineering.com](http://www.BlichmannEngineering.com)) before use.

**Caution:** Sections labeled "Caution" can lead to equipment damage or unsatisfactory performance of the equipment. Please read these sections thoroughly. If you have any questions, contact your retailer or Blichmann Engineering ([www.BlichmannEngineering.com](http://www.BlichmannEngineering.com)) before use.

**Important:** Sections labeled "Important" should specifically be followed to ensure satisfactory results with the product.

## Assembly:

A list of components included with your BrewEasy™ Adapter Lid Kit follows as well as the basic tools required for assembly. Please carefully review the lists below to ensure you received all of the correct parts and have the required tools prior to assembly.

## Parts List:

Item	Quantity	Item	Quantity
Adapter Lid (5 or 10 gallon models)	1	Bulk ½" ID Silicone Hose	1
Adapter Ring (20 gallon models)	1	½" Straight QuickConnector™	2
AutoSparge™ Level Control Valve	1	½" Elbow QuickConnector™	2
Drain Tube with QuickConnector™ Nut	1	6 piece Rubber Orifice Kit	1
Plastic Clamps	4		

## Required Tools:

Two Adjustable Wrenches



Adjustable Pliers



## Required Equipment:

### Kettles

The BrewEasy™ brewing system requires two BoilerMaker™ brew kettles, one for the mash tun and one for the boil kettle. Below is a chart to help identify which kettles are needed.

Batch Size	Mash Tun (upper kettle)	Boil Kettle (lower kettle)
5 gal (19 L)	7.5 gal	10 gal
10 gal (38 L)	15 gal	20 gal
20 gal (76 L)	30 gal	30 gal

The BoilerMaker™ brewing kettle used as the mash tun will need to be fitted with a hole to accommodate installation of the AutoSparge™ level control valve. If you are ordering a new BoilerMaker™ brewing kettle from the factory, it can be shipped with the appropriately sized hole pre-punched in one of six locations. Follow the instructions provided with the AutoSparge™ level control valve for drilling the hole yourself.

### False bottom

The mash tun (upper kettle) will require a false bottom. Select the appropriate false bottom for your size BoilerMaker™ mash tun.

### Heat Source

The BrewEasy™ requires a heat source to increase the temperature of the mash. The BrewEasy™ can be operated with either a gas burner, such as the TopTier™ floor standing burner, or an electric heating element, such as the BoilCoil™ electric immersion heater.

The TopTier™ floor standing burner can be used manually to increase and maintain the mash temperature. However, for best results and maximum repeatability, the Gas -TOWER of POWER™ temperature control module can be used.

The BoilCoil™ electric immersion heater requires the use of a control system. The Electric – TOWER of POWER™ temperature control module is recommended for optimum performance and repeatability.

### Pump

The BrewEasy™ requires the use of a pump and throttling valve, such as the March 815-HS or March 809-HS. Other pumps available in the market may be suitable for use with BrewEasy™ brewing system.

## Optional Equipment:

### TOWER of POWER™

The BrewEasy™ was designed for use with TOWER of POWER™ family of modular brewing stands and control modules. The TOWER of POWER™ modular control stands and control modules offer the ultimate in control and repeatability.

Go to <http://blichmannengineering.com/products/tower-power> learn about the TOWER of POWER™.

### KettleKart™

The KettleKart™ mobile brewing stand is the perfect answer for adding mobility to your BrewEasy™ between brews. The KettleKart™ is compatible with both electric and gas BrewEasy™ brewing systems. Visit <http://blichmannengineering.com/> for more information on how the KettleKart™ can make your BrewEasy™ brewing system even easier.

# Set-Up

## Step One:

For gas BrewEasy™ installations, place the larger kettle (boil kettle) on the burner and place the adapter lid on the top of the kettle. See Figure 1a (shown with optional KettleKart™).

For Electric BrewEasy™ installations, place the larger kettle (boil kettle) on stable surface such as the KettleKart™ (Figure 1b).

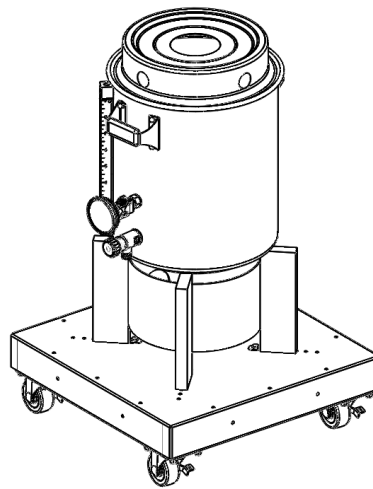

Figure 1a

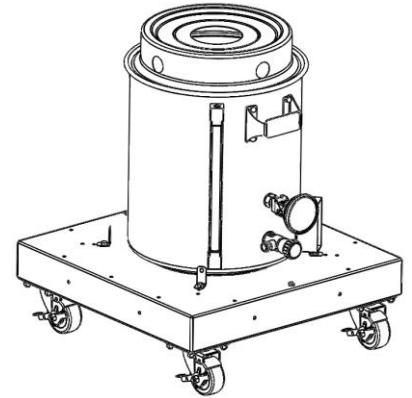

Figure 1b

**TIP:** To accommodate the installation of a QuickConnector™, orient the kettle drain valve 90° to the left or right for BoilCoil™ applications.

### Important:

Locate the boil kettle such that the outlet of the kettle is higher than the inlet of the pump.

## Step Two:

Next, install the QuickConnector™ nut over the drain tube and install one of the rubber orifices in the Quick Connector™ nut. See Figure 2. Reference the Operation section of this manual for more information on orifice selection.

Install the AutoSparge™ level control valve into the mash tun according to the instructions provided with the AutoSparge™ level control valve.

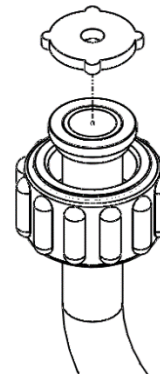

Figure 2

Place the mash tun (smaller kettle) on top of the adapter lid. Orient the drain valve of the mash tun directly above one of the vent holes in the adapter lid and install the drain tube assembly as shown. See Figure 3.

**IMPORTANT:** When installing the drain tube assembly, install the QuickConnector™ nut figure tight and secure with a no more than ½ turn. Over tightening will result in reduced flow rates.

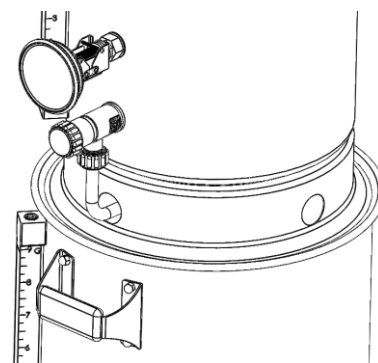
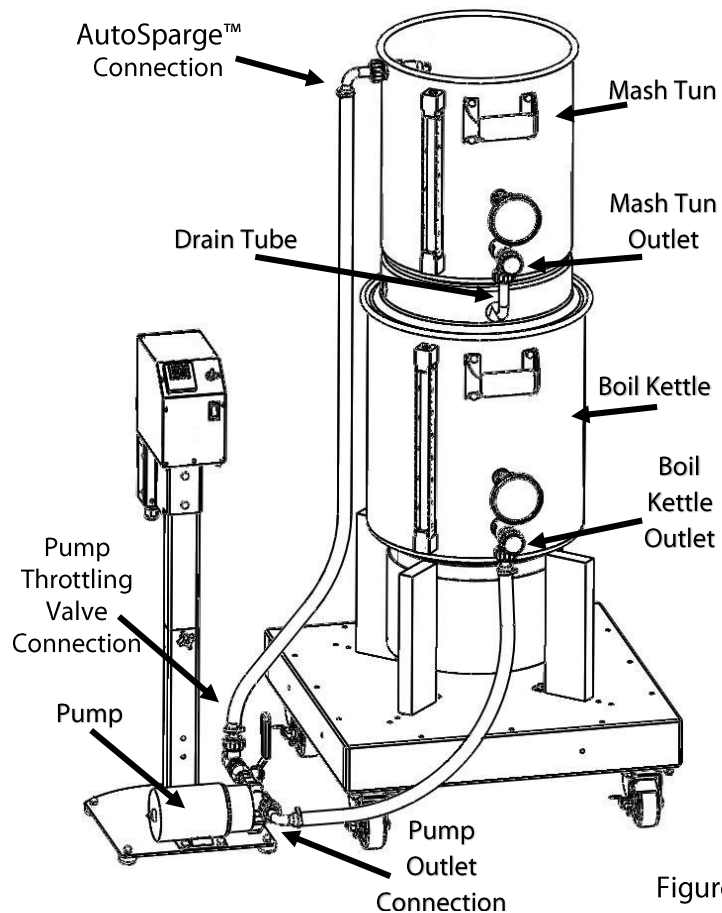

Figure 3

### Step Three:

Determine where your pump will be located. Based on the location of the pump, establish the length of hose required to connect the outlet of the boil kettle to the inlet of the pump as well as the length of hose needed to connect the outlet of the pump throttling valve to the AutoSparge™ level control valve. Cut the bulk silicone hose to the predetermined length. See Figure 4.

**IMPORTANT:** The pump in the BrewEasy™ must be located BELOW the bottom of the boil kettle (lower kettle).



\*Shown with optional accessories

### Step Four:

Install QuickConnectors™ and plastic clamps on the silicone hose cut to length in step three. Place the plastic clamp over the hose before installing the QuickConnector™. Connect the silicone hose to the supplied QuickConnectors™. On straight QuickConnectors™ leave approximately 1/8" of space between the QuickConnector™ nut and silicone hose before tightening the plastic clamp. See Figure 5.

**IMPORTANT:** Install the QuickConnectors™ in such a way that minimizes the potential for kinks that can restrict flow.

**IMPORTANT:** Locate the plastic clamp on the barbed portion of the QuickConnector™ and use adjustable pliers to fully tighten clamps.

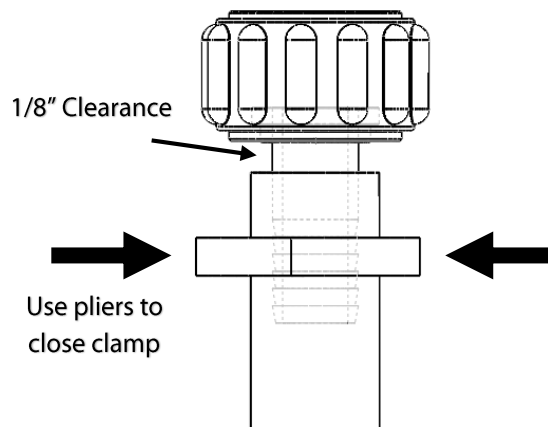

### Step Five:

Attach the assembled hoses and QuickConnectors™ to accommodate the flow of wort from the boil kettle (lower kettle) to the pump and from the pump to the mash tun (upper kettle). Below is a flow diagram indicating the correct direction of flow.

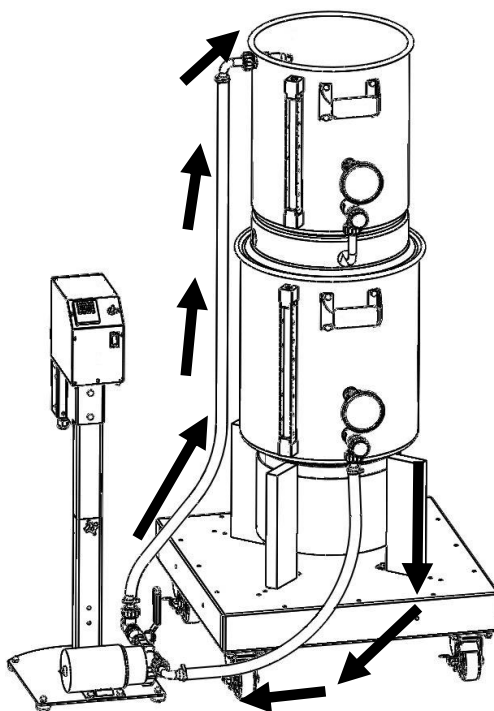

Figure 7

### Step Six:

Install the false bottom in the mash tun. Reference the BoilerMaker™ Owner's Manual for further instructions on installing the false bottom in the BoilerMaker™ brewing kettle.

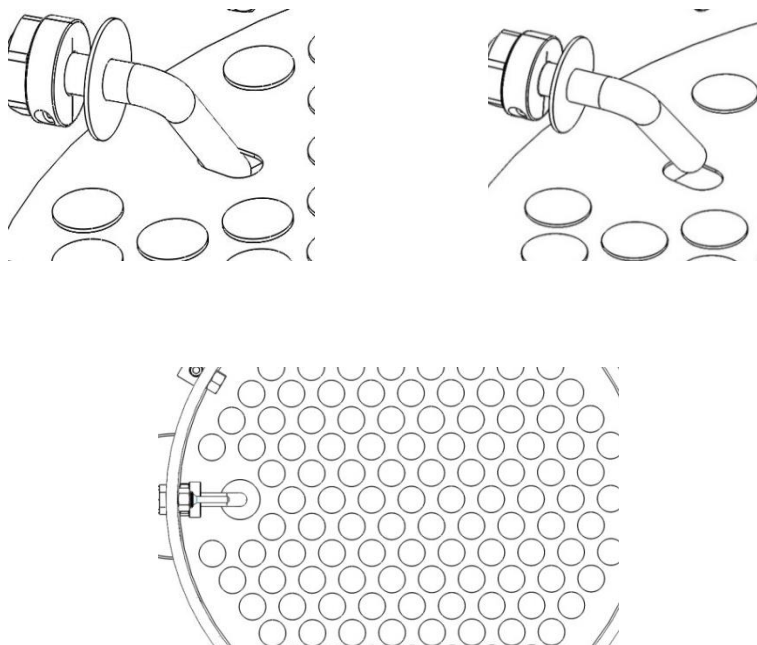

Figure 8

# Operation:

The BrewEasy™ brewing system requires continuous recirculation of wort through the mash tun to maintain accurate mash temperatures, clarify the wort, and add heat to the mash bed.

The BrewEasy™ brewing system is a sparge-less system, and therefore, all of the brewing water is added at the beginning of the process. The mash efficiency of the BrewEasy™ brewing system is generally between 68% and 72%. Mash efficiency on any system is highly dependent on crush quality, water chemistry, and grain bill among other variables. However, 70% mash efficiency is a usually a good starting point.

**Tip:** As with any new system it will take a few batches to dial in your efficiency and water usage requirements. Always make careful notes, and closely follow recommendations found in this manual. If you are new to all grain brewing we suggest reading John Palmer's book "*How to Brew*", published by the Brewers Association before your first batch. This manual is not intended to be a complete all-grain brewing text.

**IMPORTANT:** The quality of your finished beer will be directly related to the quality of your brewing water. If you have especially hard water in your area, it is strongly recommended that you dilute your tap water with distilled or reverse osmosis water or build your brewing water from scratch. For optimum results, the mash pH must fall within a range of 5.2 – 5.6 at room temperature. Additionally, a minimum of 100 ppm of Ca is required. For more information, further reading is recommended, specifically John Palmer & Colin Kaminski's book "*Water*", published by the Brewers Association.

**IMPORTANT:** We highly recommend the purchase of a digital pH meter for monitoring pH. Test strips, while inexpensive, do not provide adequate precision for brewing. Despite many pH meters being automatic temperature correcting, pH levels change with temperature. If you are reading the meter at mash temperatures, the range for mash pH is between 5.1 and 5.4 pH. This will result in a room temperature pH at the recommended range of 5.2-5.6 pH.

## System Overview

To the right is a schematic of the overall BrewEasy™ KettleRIMS™ process. Note that the system is a Recirculating Infusion Mash System (RIMS) which relies on continuous recirculation of the wort. The arrows indicate the direction and path of the continuous flow. The mash tun is positioned above the boil kettle so that it will drain by gravity from the mash tun into the boil kettle. A pump is used to move the wort from the boil kettle back into the mash tun. An AutoSparge™ level control valve to control the level of wort on the mash tun. The orifice installed in the drain tube regulates the flow rate for the

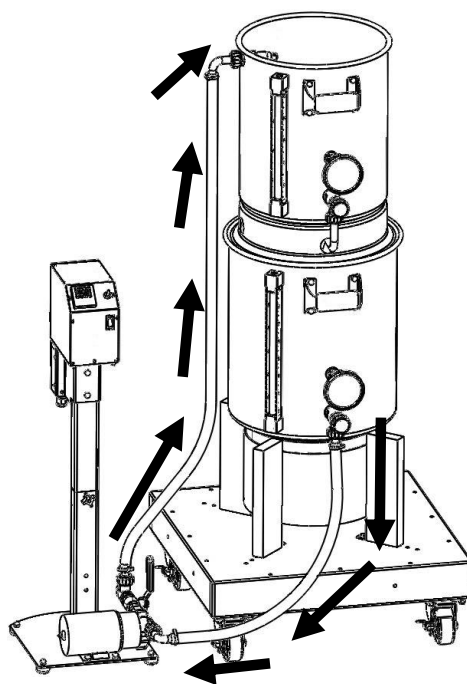

system automatically.

## Orifice Selection

Included with your BrewEasy™ is a set of 6 flow orifices ranging from 0.5 to 2.0 gpm. This orifice will set the approximate recirculation flow rate of the system automatically and allow you to simply open and close the valves fully to direct wort flow.

**Important:** It is important to flow at the fastest rate that will not cause your mash to stick. Faster flow rates increase the stability of the control system and reduces the temperature gradient in the mash. It will take some experimentation to determine which orifice is best for your system. Grain crush, adjuncts, and other variables will all have an effect on how fast you can recirculate. The chart below offers initial flow rates for different batch sizes.

Batch Size (gallons)	Approximate Recirculation Rate (gallons/minute)
5	0.75
10	1.25
20	1.5

**TIP:** The BoilerMaker™ brew kettle's level gauge can be used to warn you of an impending stuck mash. The level gauge indicates how hard you are drawing on the mash bed. If the level in the sight glass drops more than half of the starting level you are drawing too fast and are risking a stuck mash. Either install a lower flow orifice or throttle the flow using the outlet valve of the mash tun. If you experience grain bed compaction troubles, increase the size of the crush of the grain and/or incorporate rice hulls.

## Adding Water

Calculate the total water needed for the brew day. This should include grain absorption, boil off, and wort lost in your mash tun dead space, brew kettle dead space, and other downstream losses including shrinkage from cooling. The amount of brewing water is usually between 2.25 and 2.5 quarts of water per pound of grain. Brewing software such as BeerSmith2™ will help to calculate these parameters.

**TIP:** A thicker mash allows for the addition of top-up water. Too thin of a mash will require extended boiling and/or the addition of malt extract to achieve the target gravity.

Before installing the mash tun, close all valves and add all of the brewing water to the boil kettle. This is an opportune time to add any required brewing salts. Be certain to mix any mineral additions well.

**TIP:** Dissolve mineral additions in a small amount of warm water prior to adding them to the brewing water.

Install the mash tun and adjust the position of the AutoSparge™ level control valve's float arm. Set the level of the AutoSparge™ level control valve such that approximately half of the brewing water will remain in the boil kettle. Consult your AutoSparge™ manual for detailed instructions.

After installing the mash tun (upper kettle), open the drain valve on the boil kettle (lower kettle) and start the pump. As the mash tun fills with water, verify the float arm of the AutoSparge™ level control valve raises with the water level. When the AutoSparge™ level control valve reaches the closed



position, open the mash tun drain valve. Confirm the system is free of any leaks and heat the brewing water to your desired strike temperature.

**IMPORTANT:** Never fill the mash tun unattended!

## Dough-in

After the brewing water has reached the desired strike temperature, close the mash tun drain valve and turn off the pump and heat source. The float arm on the AutoSparge™ level control valve can be removed to ease the addition of grains into the mash tun. Slowly stir in the crushed grains being certain to break up any and all clumps (dough balls). After the entire grain bill has been added to the mash tun, allow a minimum of 10 minutes for air entrained in the grist to escape. Adjustment of the AutoSparge™ float arm may be necessary to accommodate the volume of grain added to the mash tun. Adjust the AutoSparge™ level control valve such that 1-2" of wort is present on top of the grain bed. After allowing the grist to settle for 10 minutes and adjusting the AutoSparge™ if necessary, open the mash tun drain valve and restart the pump.

## Mashing

After dough-in, allow the BrewEasy™ to continuously recirculate the wort for the duration of the mashing period. If controlling the mash temperature manually, monitor the BrewMometer™ installed in the mash tun (upper kettle). If the temperature of the mash tun falls below the desired temperature, ignite the burner or electric immersion heater to increase the system temperature.

**IMPORTANT:** When manually controlling the temperature of the mash tun, the temperature of the mash will continue to increase after the heat source is turned off due to the mass of the grist. Always turn off the heat source before the mash tun BrewMometer™ indicates the desired temperature. Add heat for shorter intervals as the mash tun temperature approaches the desired temperature.

For the pinnacle in brewing control, the TOWER of POWER™ family of modular brewing stands and temperature control modules can be incorporated with the BrewEasy™ KettleRIMS™ brewing system. Use the TOWER of POWER™ temperature control module can be used in conjunction with the full featured TOWER of POWER™ control module stand for the ultimate in brewing control or with the TOWER LTE™ modular control stand for those looking for a more compact solution.

**Tip:** If excessive water is spraying out the end of the AutoSparge™ level control valve, this can be quickly corrected by partially closing (throttling) the pump flow valve until the bypass flow is reduced. Some bypass is normal and is not detrimental to the wort.

## Mash-out

After the saccharification rest is complete, heat the mash to the desired mash-out temperature using the same method described in the Mashing section of this manual. Allow the mash to rest at the mash-out temperature for an adequate amount of time to stop enzymatic activity. Generally, a minimum of ten minutes for the mash-out is required to denature saccharification enzymes.

After the completion of the mash-out stage, allow the wort to drain into the boil kettle. Draining the wort from the mash tun to the boil kettle is achieved by simply turning off the pump, closing the boil kettle drain valve, and leaving the mash tun drain valve open.

## Boil

Once all of the wort has been collected in the boil kettle, close the mash tun drain valve. Remove the drain tube assembly and hose connected to the AutoSparge™. Carefully remove the spent grains from the mash tun using appropriate personal protective equipment, such as long sleeves, long pants, shoes, and gloves. Blichmann Engineering™ brewing gloves can help you avoid burns and scalds and can be purchased from your retailer. Remove the mash tun and proceed to your boil schedule.

## Tips for Success

- Adding grains while the pump is on will likely cause the pump to airlock and the mash to stick! Always turn off the heat source, turn off the pump, and close all valves prior to adding the grains.
- If excessive water is spraying out the end of the AutoSparge™ level control valve, this can be quickly corrected by partially closing (throttling) the pump flow valve until the bypass flow is reduced. Some bypass is normal and is not detrimental to the wort.
- Do not skip the pH measurements! If your mash is much above the recommended pH you risk astringency in your beer among other detrimental changes. Adding water salts and acid may be necessary to achieve proper pH in any all-grain brewing system.
- During dough-in, an occasional gentle stirring will break up any clumps and release air pockets. The dough-in process is vital for problem free recirculation.
- Stir (rake) the top 1/3 of the mash bed about every 15 minutes to break up any channels in the mash bed that may have formed. Do NOT disturb the bottom 2/3's of the bed as this is acting as the filter in the system. Periodically raking the mash will increase your efficiency and ensure an even temperature throughout the mash bed for more repeatable results.
- Let the grain sit (dough-in) for about 10 min to absorb the liquor and for the air to purge out of the grain. Turning on the pump before this dough-in process is complete will likely cause an airlock in the pump and a stuck mash!
- Do not skip the pH measurements! If your mash is much above the recommended pH you risk astringency in your beer among other detrimental changes. Adding water salts and acid may be necessary to achieve proper pH in any all grain brewing system.
- After the wort has stabilized at the desired mash temperature, take a pH measurement using a quality digital pH meter. Your pH should be between 5.1 and 5.4 pH when measured at mash temperatures (145-160F, 63-71C). If the sample has cooled to room temperature your reading should be in the 5.2-5.6 pH range. If your mash is not in the desired range you will need to add more calcium into your mash or add an acid (we recommend phosphoric) to acidulate the mash.
- Consult the two recommended books, *How to Brew* and *Water* by John Palmer and Colin Kaminski (published by the Brewers Association) to learn how to properly adjust your mash pH.
- Measure the specific gravity periodically. The SG of the mash is the same as the pre-boil wort SG. Make adjustments to your wort such as adding malt extract, water, or mashing longer to achieve the desired SG of the pre-boil wort.

# After Use Cleaning, Storage, and Maintenance:

Cleaning of the BrewEasy™ system is very straight-forward. Clean the adapter lid with a mild detergent (non- chlorine) or Powdered Brewery Wash (PBW) after use. Rinse the drain tube with hot water or soak in a pail of PBW to remove any soils inside the tube. Soak the hoses in a PBW solution, rinse with hot tap water and soak in a non-chlorine sanitizer. Hang to dry. Note: Iodophor will leave a harmless brown stain on the hoses. StarSan, our recommended sanitizer, will not cause any staining. Please consult the individual product manuals for cleaning of the BoilerMaker™ brewing kettles and the TOWER of POWER™ control module stand or TOWER LTE™ modular control stand and pumps.

## Blichmann Engineering Product Warranty

### A. Limited Warranty

1. Blichmann Engineering warrants to the original purchaser that this product will be free from manufacturing defects in material and workmanship for a period of one (1) year from the date of purchase by the customer. Proof of purchase is required. Blichmann Engineering's obligation to repair or replace defective materials or workmanship is the sole obligation of Blichmann Engineering under this limited warranty.
2. This product is for home use only. The limited warranty covers only those defects that arise as a result of normal use of the product and does not cover any other problems, including, but not limited to, those that arise as a result of:
  - a. *Improper maintenance or modification;*
  - b. *Damage due to incorrect voltage or improper wiring by customer;*
  - c. *Operation outside of the product's specifications;*
  - d. *Carelessness or neglect to operate the product in accordance with instructions provided with the product;*
  - e. *Damaging the tamper label on the product;*
  - f. *Damage by over-tightening the fasteners;*
  - g. *Failure to follow cleaning and / or maintenance procedures;* or
  - h. *Exceeding published operational temperatures.*
3. Blichmann Engineering reserves the right to request delivery of the defective component for inspection before processing the warranty claim. If Blichmann Engineering receives, during the applicable warranty period, notice of a defect in any component that is covered by the warranty, Blichmann Engineering shall either repair or replace the defective component with a new or rebuilt component at Blichmann Engineering's option.
4. Blichmann Engineering must be notified within seven (7) days of the delivery date of any shipping damage. Customer is responsible for shipping damage outside of this time period. Approval for return must be provided by Blichmann Engineering prior to any return. Customer is responsible for keeping all original packaging material for warranty returns. Blichmann Engineering is not responsible for damage from improperly packaged warranty returns, and these repair costs will be the sole responsibility of the customer. Shipping costs for warrantee returns are covered only for the contiguous United States.
5. Blichmann Engineering's limited warranty is valid in any country where the product is distributed.

---

### B. Limitations of Warranty

1. Any implied warranty that is found to arise by way of state or federal law, including any implied warranty of merchantability or any implied warranty of fitness, is limited in duration to the terms of this limited warranty and is limited in scope of coverage to this warranty. Blichmann Engineering disclaims any express or implied warranty, including any implied warranty of fitness for a particular purpose or merchantability, on items excluded from coverage as set forth in this limited warranty.
2. Blichmann Engineering makes no warranty of any nature beyond that contained in this limited warranty. No one has authority to enlarge, amend, or modify this limited warranty, and Blichmann Engineering does not authorize anyone to create any other obligation for it regarding this product.
3. Blichmann Engineering is not responsible for any representation, promise, or warranty made by any independent dealer or other person beyond what is expressly stated in this limited warranty. Any selling or servicing dealer is not Blichmann Engineering's agent, but an independent entity.

---

### C. Limitations of Liability

1. The remedies provided in this warranty are the customer's sole and exclusive remedies.
2. Except for the obligations specifically set forth in this warranty, in no event shall Blichmann Engineering be liable for direct, indirect, special, incidental, or consequential damages, whether based on contract, tort, or any other legal theory and whether or not advised of the possibility of such damages.
3. This warranty does not cover, and in no event shall Blichmann Engineering be liable for, travel, lodging, or any other expense incurred due to manufacturing defects in material and workmanship, or any other reason.
4. Any performance of repairs after the warranty coverage period has expired or performance of repairs regarding anything excluded from coverage after this limited warranty shall be considered good-will repairs and they will not alter the terms of this limited warranty, or extend any warranty coverage period.
5. Venue for any legal proceedings relating to or arising out of this warranty shall be in Tippecanoe County, Indiana, United States, which courts will have exclusive jurisdiction.

---

### D. Local Law

1. This warranty gives the customer specific legal rights. The customer may also have other rights that vary from state to state in the United States or other countries.
2. To the extent that this warranty is inconsistent with local law, it shall be deemed modified, only to the extent necessary to be consistent with such local law.