



Water Coolers



REMOTE WATER CHILLERS

R1P

Suggested Specification

Remote drinking water chiller shall deliver at least 1.0 gph of water at 50° F cooled from 80° F inlet water at 90° F ambient. Evaporator shall be copper evaporator tube on stainless steel water storage tank and both shall be encapsulated in insulation. Total water system shall be stainless steel. R-134a refrigerant system shall be hermetically sealed and refrigerant flow shall be capillary tube controlled. An adjustable thermostat having an off position shall control refrigeration system. Potable water system components shall comply with Safe Drinking Water Act Amendments, the 1988 Lead Contamination Control Act and shall be Certified to ANSI 61 Section 9. Cooler shall be Listed by Underwriters Laboratories Inc. to U.S. and Canadian safety standards. Drinking water chiller shall be Oasis model R1P.

Standard Features

- > Powder coated galvanized steel cabinet with plastic front
- > Air-cooled; designed to fit under a sink
- > Compact, economical and easily installed
- > Four foot (4') insulated power cord with NEMA 5-15 plug
- > Stainless steel storage tank
- > 1/4" OD stainless steel water tube connections
- > Welded water lines to eliminate corrosion and assure leakproof operation
- > HFC Refrigerant R-134a
- > Product Certified to NSF/ANSI Standard 61, Annex G (AB1953)



Components in these water coolers are lead free as defined by the Safe Water Act Amendments of 1986, and the Lead Contamination Control Act of 1988.

Limited 1-Year Warranty (Continental limits of the United States and Canada): One year from the date of installation. Detailed warranty certificate enclosed with each drinking fountain; sample copy available upon request.

Export Warranty: One year on component parts. Detailed warranty certificate enclosed with each drinking fountain; sample copy available upon request.

Product Certified to NSF/ANSI Standard 61, Annex G (weighted average lead content of $\leq 0.25\%$) and is in compliance with California's Health & Safety Code Section 116875 (commonly known as AB1953).

Model covered by this specification complies with all known Plumbing Codes. Listed by Underwriters' Laboratories to U.S. and Canadian standards and conform to European Union Directives.



Certified to NSF/ANSI 61-G

Model	50° F Drinking Water 90° F Ambient Air Temp*			Hot 'N Cold™ Model	115 Volts, 60 HZ			Glass Filler Acc. Option	Cabinet Color Finish	Net Wt. Approx.
	Cooling Capacity GPH	Base Rate GPH	Pre-Cooler		Compr. HP	Full Load Amps	Rated Watts			
R1P	1	n/a	n/a	n/a	1/20	1.3	135	n/a	White/gray	30 Lbs.

*Industry Standard Rating Condition 80° F inlet water temperature.

Specifications subject to change without notice

OASIS™ REMOTE WATER CHILLER R1P

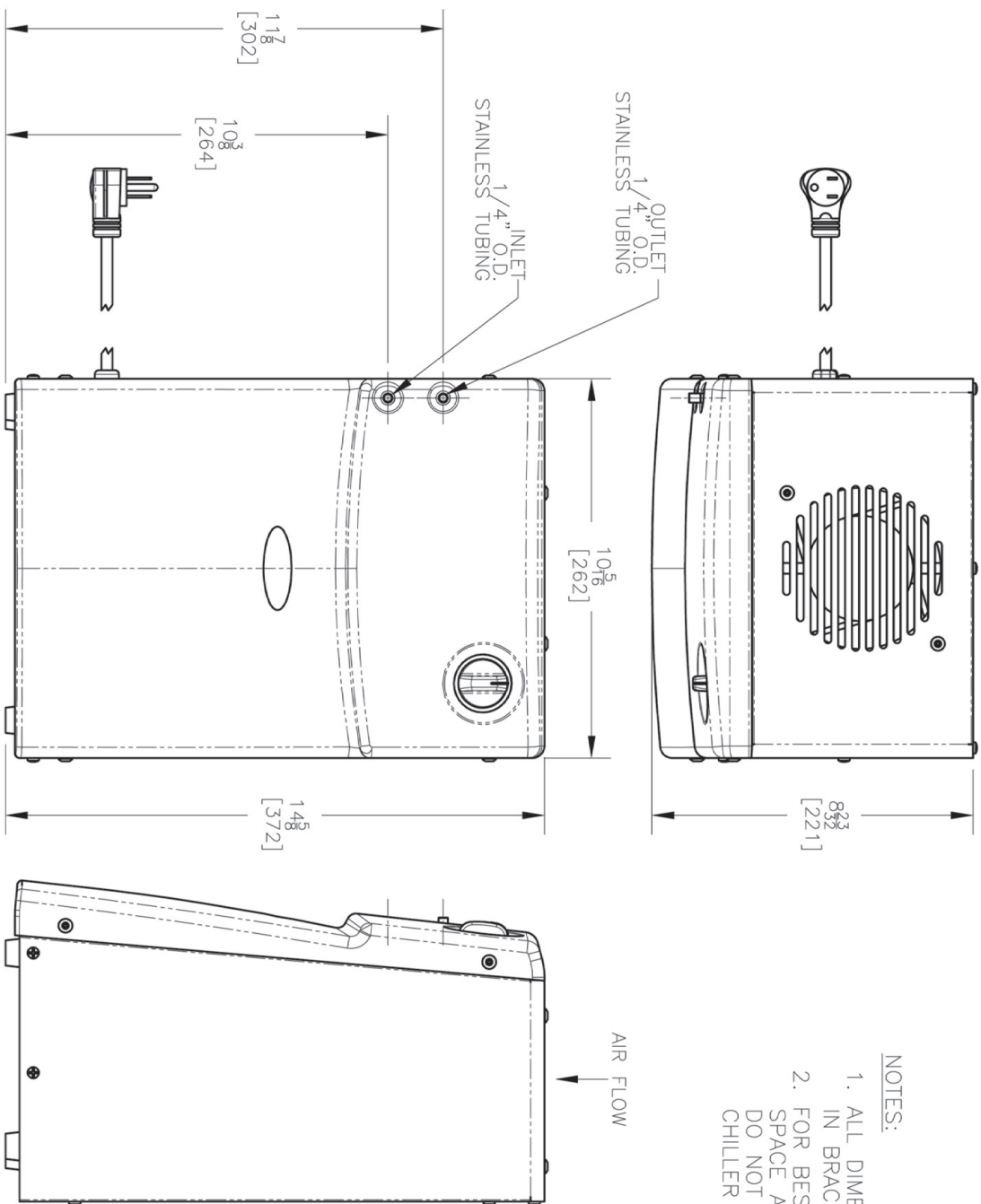

NOTES:

1. ALL DIMENSIONS ARE IN INCHES. DIMENSIONS IN BRACKETS [] ARE IN MILLIMETERS.
2. FOR BEST PERFORMANCE, ALLOW A 2" [51] SPACE AROUND THE SIDE AND THE TOP. DO NOT PUT ANY OBJECTS ON TOP OF THE CHILLER THAT COULD OBSTRUCT THE FAN.



THIRD ANGLE PROJECTION

ROUGHING-IN AND DIMENSIONAL DRAWING