



WINEMATE Cooling Unit

Use & Care Manual

WM1500 HTD

WM2500 HTD

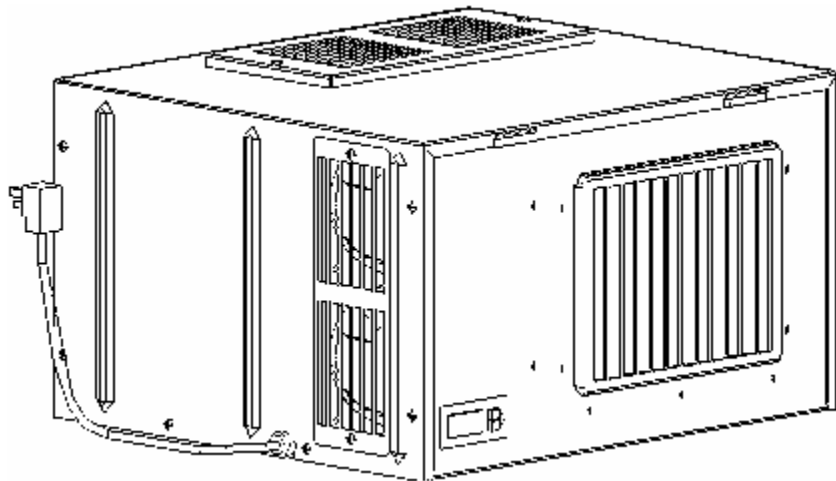

Vinotemp International Corp.

www.vinotemp.com

READ AND SAVE THESE INSTRUCTIONS

TABLE OF CONTENTS

Important Safety Information.....	2
Feature Description.....	3
Installation Instruction.....	5
Temperature & Humidity Control.....	8
Care Guide.....	11
Troubleshooting.....	16
Wiring Diagram.....	18
Customer Support.....	19
Warranty.....	20
Appendix.....	22

Important Safety Information

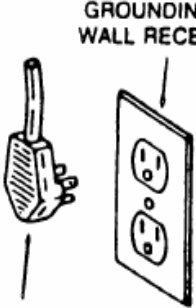
! WARNING	
	
To avoid the risk of electrical shock, property damage, personal injury or death:	
<ul style="list-style-type: none">• The power cord must be plugged into a 3-prong grounding-type wall receptacle, grounded in accordance with the National Electrical Code, ANSI/NFPA 70 - latest edition and local codes and ordinances.• It is the personal responsibility of the consumer to have a proper 3-prong wall receptacle installed by a qualified electrician.• DO NOT, UNDER ANY CIRCUMSTANCES, REMOVE THE POWER CORD GROUNDING PRONG.• A separate adequately fused and grounded circuit should be available for this appliance.• Do not remove any grounding wires from individual components while servicing, unless the component is to be removed and replaced. <i>It is extremely important to replace all grounding wires when components are replaced.</i>	
	<p>GROUNDING TYPE WALL RECEPTACLE</p> <p>POWER SUPPLY CORD WITH 3-PRONG GROUNDING PLUG</p>

! WARNING	
	ELECTRIC SHOCK HAZARD Disconnect electric supply from appliance before servicing. Replace all panels before operating. Failure to do so could result in death or electrical shock.

- **DO NOT PLUG IN UNTIL 24 HOURS AFTER DELIVERY.**
- **DO NOT USE A GROUND FAULT INTERRUPTER (GFI).**
- **A DEDICATED 15 AMP CIRCUIT IS HIGHLY RECOMMENDED.**

Feature Description

- WM1500 & 2500 HTD cooling unit is designed and used to provide a subtle temperature between 50~65 °F for suitable space at a normal environment.
- The refrigerated space will maintain humidity of 50~70% RH even when the environment becomes dry and humid.
- These temperatures and humidities are optimized for long term storage of wine, fur and tobacco.
- Humidity and temperature digital control using patent pending technology
- Optimized air flow for most even temperatures in wine cabinets
- Exchangeable discharge grille for front, back and down cold air distribution
- Multiple exhaust for top and rear hot air exhaust
- High efficient tube-axial fans for both condenser and evaporator
- Extra insulation for both thermal and noise isolation
- Unique condensate drain tray for humidity control
- Grill size optimized for easy cleaning and safety
- Stamping housing for robust structure
- Self-contained ready for use and easy for installation

1. COLD-AIR DISCHARGE
2. RETURN-AIR INTAKE
3. AMBIENT-AIR INTAKE
4. HOT-AIR BACK EXHAUST
5. HOT-AIR TOP EXHAUST
6. DIGITAL CONTROLLER
7. POWER CORD

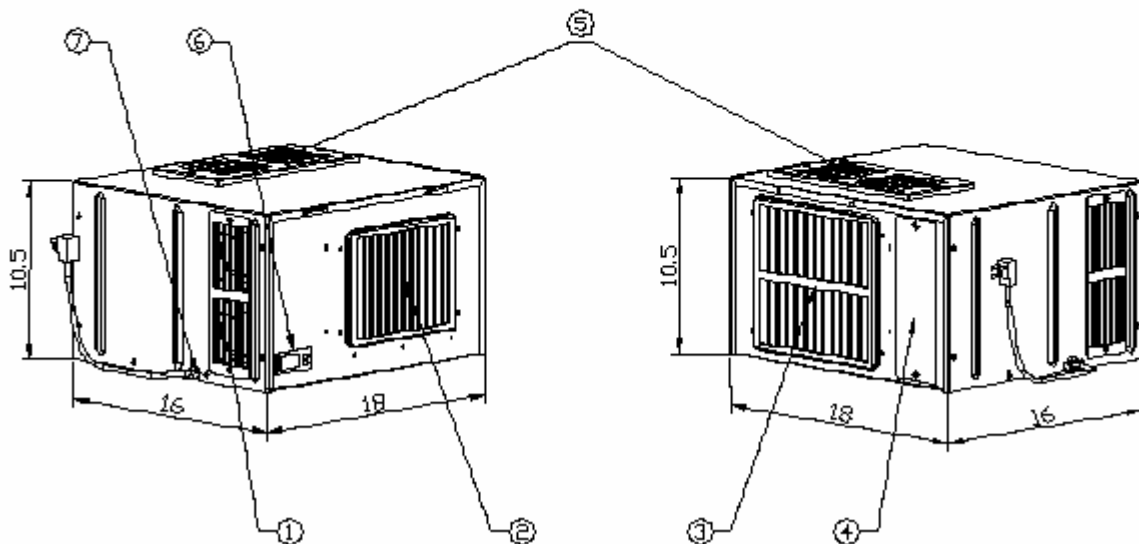

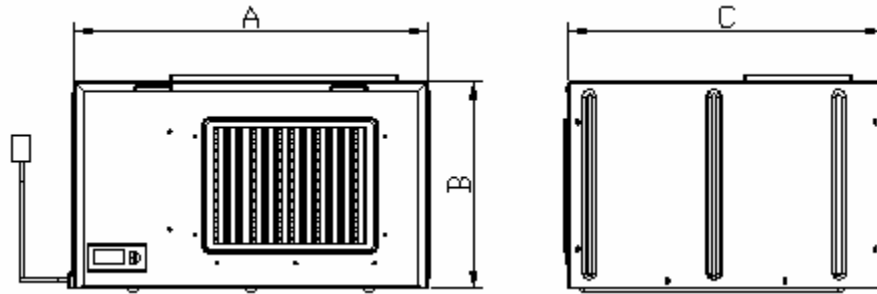

Dimensions: A = 18"; B = 10.5"; C = 16"

The dimension and capacity are specified as follows:

Model	Description	Capacity		Electrical	Weight
1500htd	Rear Exhaust	Up to 150 cu ft	800 bottles	115V 60Hz 4A	55 lb
1500htd- te	Top Exhaust	Up to 150 cu ft	800 bottles	115V 60Hz 5A	55 lb
2500htd	Rear Exhaust	Up to 250 cu ft	1200 bottles	115V 60Hz 4A	60 lb
2500htd- te	Top Exhaust	Up to 250 cu ft	1200 bottles	115V 60Hz 5A	60 lb

- **See the voltage, frequency and amp from the label on the back of the cooling unit.**

Installation Instruction

WARNING



Always check wiring harness connections before initiating any test procedures.

Disconnect electric power from the appliance before performing any maintenance or repairs.

Voltage checks should be made by inserting meter probes beside the wires in the connector blocks with the electric power source on and the connector block plugged in.

Resistance checks should be made on components with the electric power off and the connector block disconnected.

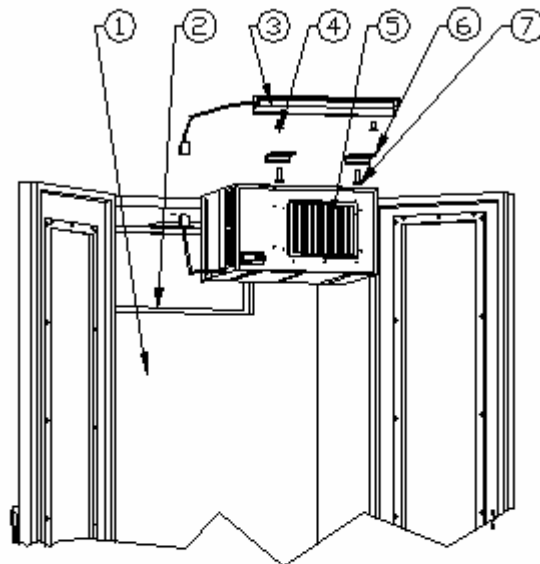

1. CELLAR
2. GASKET
3. LIGHT
4. SCREW (USED FOR 3)
5. COOLING UNIT
6. BRACKET (USED FOR 5)
7. SCREW (USED FOR 6)

1. Location

- Place the refrigerated enclosure such as wine cellar in a properly ventilated location. If it is not, heat exhausted by the cooling unit will build up and the cooling unit will not operate properly.
- Leave 4~6 "clearance between the exhaust side and the wall or ceiling.
- Leave 2~4" clearance for the fresh air supply side.
- Leave 1~2" for the other sides.

2. Installation

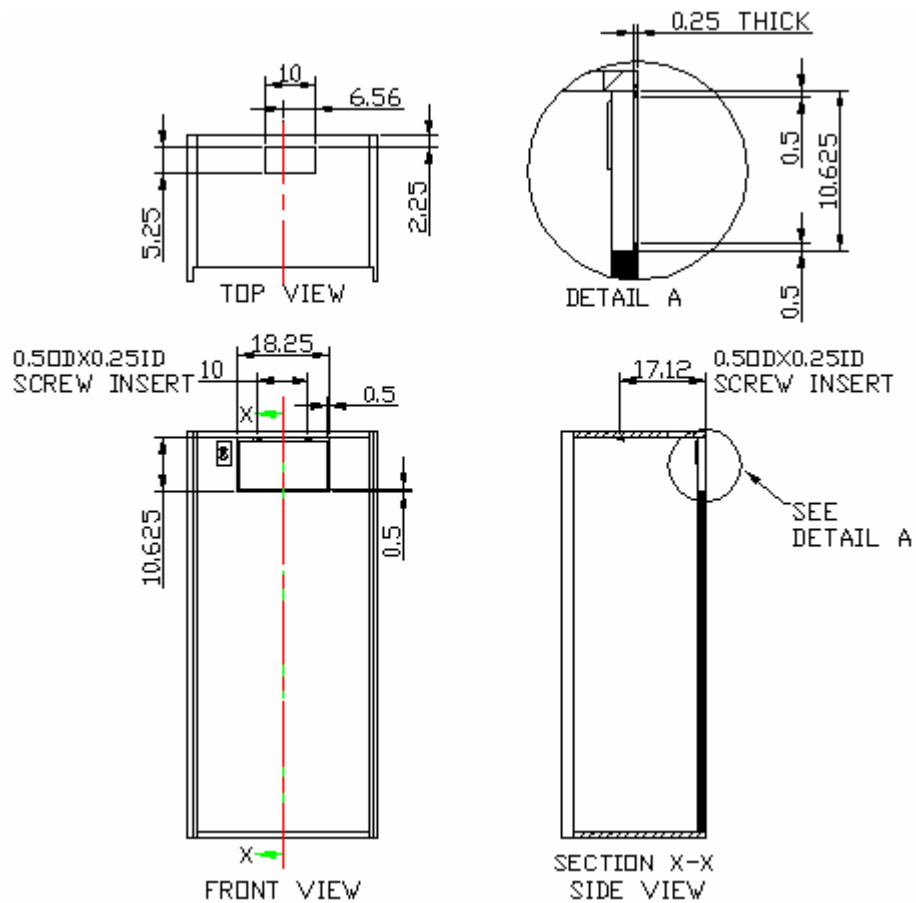



- Cut a rectangular opening with the ¼” clearance inwards to the width and height of the cooling unit, the opening is positioned from the top and center of the cabinet.
- If top exhaust, cut a rectangular opening to the length and width of the top exhaust openings at the top of the cabinet.
- Mount the gaskets on the four rear mounting sides.
- If top exhaust, place the gaskets along the top openings at the top of the cooling unit.
- Place the cooling unit to a flat and stable place.
- Then move it on the top of the rack temporarily.
- Move the cooling unit towards the mounting sides and push to press the gasket.
- Locate the 2 brackets (6) and use 7/16” wrench to tighten the 2 screws (7).
- If top exhaust, install the top exhaust grille at the top of the cabinet with the arrow towards the front and facing down the cabinet.
- Plug the Wine-mate cooling unit in receptacle.
- Screw the 2 screws (4) and locate the light on the ceiling.
- Plug the light in receptacle.
- Plug the wine cellar.

3. Electrical Cord

- Because of potential safety hazards under a certain condition, we strongly recommend against the use of an extension cord. However, if you still elect to use an extension cord, it is absolutely necessary that it will be a UL LISTED 3-wire grounding type appliance extension cord having a 3-blade grounding plug and a 3-slot receptacle that will plug into the appliance. The marked rating of the extension cord should be 115 V, 15 A.

Temperature & Humidity Control

1. Temperature Setting

- Set the temperature at 55 °F for the optimum aging of wine
- Set the temperature higher at very high ambient temperature.
- On initial start-up, the time required to reach the desired temperature will vary, depending on the quantity of bottles, temperature setting and surrounding temperature.
- Allow 24 hours to stabilize the temperature for each new temperature setting operation

2. Use of the controller



1) Display

During normal operating conditions, the display shows the value measured by the air regulation probe. In case of active alarm, the temperature flashes alternately to the code alarm.

1.1 LED Functions

LED	MODE	FUNCTION
❄️	ON	Compressor enabled
❄️	Flashing	Anti-short cycle delay enabled
❄️	ON	Defrost enabled
🔊	ON	An alarm is occurring
°C/°F	ON	Measurement unit
°C/°F	Flashing	Programming phase

1.2 Front Panel Commands

SET: To display target set point; in programming mode it selects a parameter or confirm an operation.



 **(DEF)** To start a manual defrost

 **(UP)**: To see the max. stored temperature; in programming mode it browses the parameter codes or increases the displayed value.

 **(DOWN)** To see the min stored temperature; in programming mode it browses the parameter codes or decreases the displayed value.

O/I To turn ON or OFF the controller (if enabled)

KEY COMBINATIONS:

 +  To lock & unlock the keyboard.

SET +  To enter in programming mode.

SET +  To return to the room temperature display.

2) Alarm Signals

2.1 Code Description

Message	Cause	Outputs
"P1"	Room probe failure	Compressor output acc. to par. "Con" and "COF"
"HA"	Maximum temperature alarm	Outputs unchanged.
"LA"	Minimum temperature alarm	Outputs unchanged.
"CA"	Serious external alarm (i1F=bAL)	All outputs OFF.

2.2 Alarm Recovery

Probe alarms P1", start a few seconds after the fault in the related probe; they automatically stop a few seconds after the probe restarts normal operation. Check connections before replacing the probe. Temperature alarms "HA", "LA" automatically stops as soon as the temperature returns to normal value. Alarm "CA" (with i1F=PAL) recovers only by switching off and on the instrument.

3) Temperature Set-Point







3.1 How to see the set-point

1. Push and immediately release the SET key: the display will show the Set-point value;
2. Push and immediately release the SET key or wait for 5 seconds to display the probe value again.

3.2 How to change the set-point

1. Push the SET key for more than 3 seconds to change the Set point value;
2. The value of the set point will be displayed and the “°C” or “°F” LED starts blinking;
3. To change the Set value, push the o or n arrows within 10s.
4. To memorize the new set point value, push the SET key again or wait 10s.

4) Humidity Adjustment



1. Press the **Set** +  keys for 3 sec. (the “°C” or “°F” LED starts blinking).
2. Release the keys, then push again the **Set** +  keys for more than 7sec, the **Pr2** label will be displayed immediately followed from the **HY** parameter.
3. Select the required parameter **Fon** by up or down keys  .
4. Press the “**SET**” key to display its value.
5. Use up or down keys   to change its value.
6. The default value is 5, change high or low value to maintain high or low humidity.
7. Press “**SET**” to store the new value.
8. **To exit:** Press **SET** +  or wait 15sec without pressing a key.

5) Manual Defrost

Push the DEF key for more than 2 seconds and a manual defrost will start.

Care Guide

I. Component Identification

 WARNING	
	ELECTRIC SHOCK HAZARD
	Disconnect the electrical power before servicing any components. Failure to do so can result in death or electrical shock.

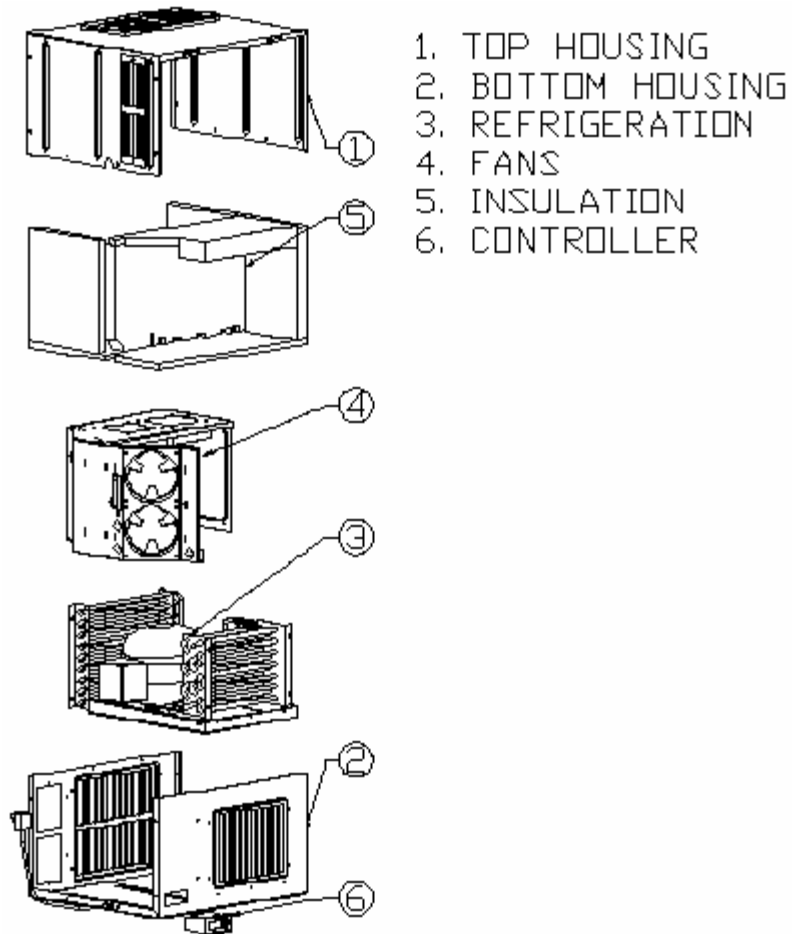

Exploded View

1) Removing the Outer Cover

1. Unplug the WINEMATE cooling unit or disconnect power.
2. Remove the WINEMATE cooling unit from the enclosure.
3. Remove 6 screws from each side then remove the outer cover.

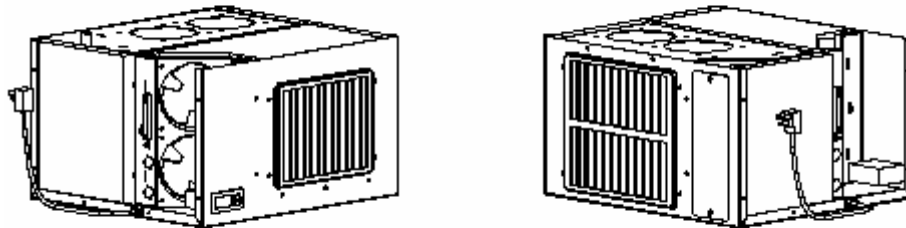

2) Removing the Styrofoam

Once the outer cover is removed, this will expose 6 pieces of styrofoam. To gain access to the other components, the styrofoam parts will need to be removed. The top styrofoam seals off the compressor, condenser and evaporator compartments.

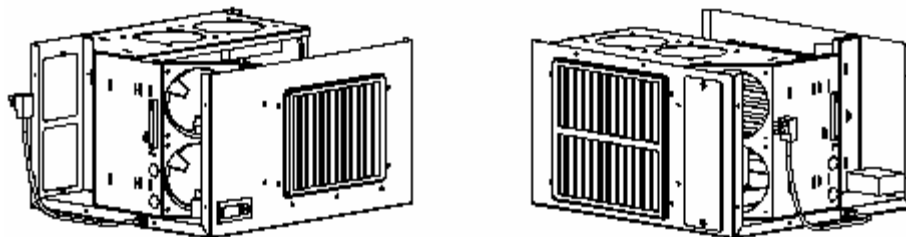

3) Removing the Electrical Controller

1. Unplug the WINEMATE cooling unit or disconnect power.
2. Remove WINEMATE cooling unit from the enclosure opening
3. Remove the outer cover and top styrofoam.
4. Disconnect all three connectors for the electronic controller.
5. Unsnap the thin plastic cover off the front of the electronic controller.

6. Remove the two screws from the front of the electronic controller.
7. Locate the retainer just inside the front panel going around the outside of the electronic controller. While squeezing both tabs of the retainer, push the electronic controller out of the opening.

4) Removing the Thermistor

1. Unplug the WINEMATE cooling unit or disconnect power.
2. Remove the WINEMATE cooling unit from the enclosure opening.
3. Remove the outer cover.
4. Remove the top styrofoam.
5. Disconnect the thermistor with connector from the electronic controller.
6. Remove the thermistor from the mounting clip on the front of the evaporator.

4) Removing the Fans

1. Unplug the WINEMATE cooling unit or disconnect power.
2. Remove the WINEMATE cooling unit from the enclosure opening.
3. Remove the outer cover.
4. Remove all styrofoam parts.
5. Disconnect the two wires going to the electronic junction block and other two wires to the electronic controller.
6. Remove the all screws holding the side and top fan shrouds

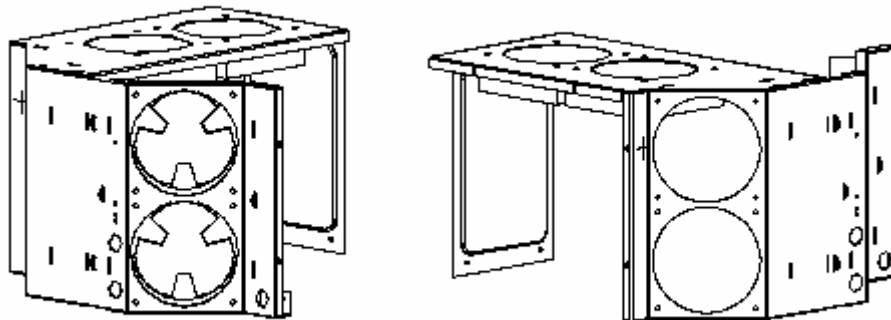

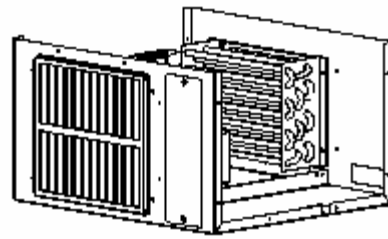
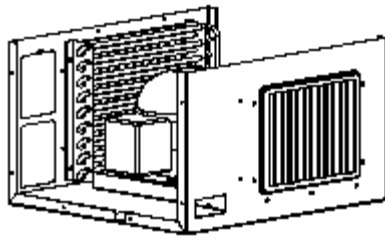

6) Removing the Compressor

1. Unplug the WINEMATE cooling unit or disconnect power.
2. Remove the WINEMATE cooling unit from the enclosure opening.
3. Remove the outer cover.
4. Remove the side and top styrofoam parts.
5. Remove the side and top fan shrouds.
6. Place piercing valves onto the process tubes and discharge the refrigerant into an approved R134a recovery system.
7. Use a tubing cutter to remove the suction line and discharge line from the compressor.
8. Remove 4 hitch clips from the feet of the compressor.
9. Remove the compressor

Note: Any time the sealed system is accessed the filter-drier must be replaced. It is best to cut the drier out of the system, then braze on a new one.

7) Removing the Condenser

1. Unplug the WINEMATE cooling unit or disconnect power.
2. Remove the WINEMATE cooling unit from the enclosure opening.
3. Remove the outer cover.
4. Remove the side and top styrofoam parts.
5. Remove side and top fan shrouds.
6. Place piercing valves onto the process tubes and discharge the refrigerant into an approved R134a recovery system.
7. Use a tubing cutter to remove the hot gas line and liquid line from the condenser.
8. Remove 4 rivets from the condenser.
9. Remove the condenser

8) Removing the Evaporator

1. Unplug the WINEMATE cooling unit or disconnect power.
2. Remove the WINEMATE cooling unit from the enclosure opening.
3. Remove the outer cover.
4. Remove the side and top styrofoam parts.
5. Remove side and top fan shrouds
6. Place piercing valves onto the process tubes and discharge the refrigerant into an approved R134a recovery system.
7. Cut the capillary line and suction line from the evaporator.
8. Remove 4 rivets from the evaporator.
9. Remove the evaporator.

II. Coil Cleaning

- Clean the condenser coil regularly. Coil may need to be cleaned at least every 6 months.
- Coil is on the back of the wine cellar.
- Unplug the cellar or disconnect power.
- Use a condenser brush or a vacuum cleaner with an extended attachment to clean the coil when it is dusty or dirty.
- Plug wine cellar or reconnect power.

III. Moisture Removing

- Remove the extra condensate if it is accumulated in the wine cellar at high ambient temperature and humidity.

Troubleshooting

This Troubleshooting Chart is not prepared to replace the training required for a professional refrigeration service person, not is it comprehensive

Troubleshooting Chart

Complaint	Possible Causes	Response
1. Unit not running		
	<ul style="list-style-type: none"> a. Power cord unplugged b. No power to unit c. Temperature setting high d. Low voltage. e. Incorrect or loose wirings. f. Defrost light blinking g. Running light blinking 	<ul style="list-style-type: none"> a. Check for power cord plug b. Check power at receptacle & fuses c. Lower temperature setting d. Contact an authorized electrician e. Check all wirings and connections f. Under defrost g. Call service for failed components
2. Compressor stopping and starting but short running time		
	<ul style="list-style-type: none"> a. Incorrect temperature setting b. Incorrect voltage c. Failed thermistor d. Failed components e. Improper condenser airflow f. Dirty condenser g. Overcharge of refrigerant h. Discharge or suction pressure too high 	<ul style="list-style-type: none"> a. Set 55 to 60 °F b. Check for voltage c. Check thermistor by placing it in ice water and measuring resistance d. Check compressor windings, start relay and overload protector. e. Check for condenser fan f. Clean condenser g. Call service for removing refrigerant h. Call service for OEM information
3. Fan motor running but compressor not running		
	<ul style="list-style-type: none"> a. Incorrect power supply b. Incorrect or loose wirings c. Failed components d. Liquid refrigerant in the compressor 	<ul style="list-style-type: none"> a. Check for proper voltage b. Check all wirings and connections c. Check start relay, start capacitor, overload protector, compressor. d. Call service for OEM information.
4. Compressor running but fan not running		
	<ul style="list-style-type: none"> a. Fan blade bond b. Incorrect or loose wirings c. Failed motors 	<ul style="list-style-type: none"> a. Check for proper clearance b. Check all wirings c. Call service for checking open or shorted windings
5. No cooling but compressor and fan running		
	<ul style="list-style-type: none"> a. Evaporator airflow restriction b. Refrigerant leakage c. Refrigeration system restriction 	<ul style="list-style-type: none"> a. Check for airflow through evaporator b. Check for loss of refrigerant c. Call service for checking restrictions
6. Temperature too high or unit running too long		
	<ul style="list-style-type: none"> a. Improper evaporator or condenser airflow b. Dirty Condenser c. Iced evaporator d. Malfunctioning fans e. Improper seals f. Improper area to be cooled. 	<ul style="list-style-type: none"> a. Check for air restrictions b. Clean condenser c. Defrost and reset temperature d. Check for both fans e. Check for gasket and door opening f. Check for excessive load incorrect installation

	<ul style="list-style-type: none"> g. Low voltage h. Operating 60 Hz unit at 50Hz i. Sealed system problem j. Undercharge or overcharge 	<ul style="list-style-type: none"> g. Check power supply h. Use proper 60 Hz i. Call service for checking loss of refrigerant or restrictions j. Call service to add or remove refrigerant
7. House circuit tripping		
	<ul style="list-style-type: none"> a. Incorrect fuse or breaker b. Incorrect wirings c. Failed components 	<ul style="list-style-type: none"> a. Check for proper fuse or breaker b. Check for wirings and connections c. Call service
8. Noisy operation		
	<ul style="list-style-type: none"> a. Mounting area not firm b. Loose parts c. Compressor overloaded due to high ambient temperatures or airflow restriction d. Malfunctioning components 	<ul style="list-style-type: none"> a. Add support to improve installation b. Check fan blades, bearings, cabinet washers, tubing contact and loose screws. c. Check for airflow blockage d. Call service for checking Internal loose, inadequate lubrication and incorrect wirings

Wiring Diagram

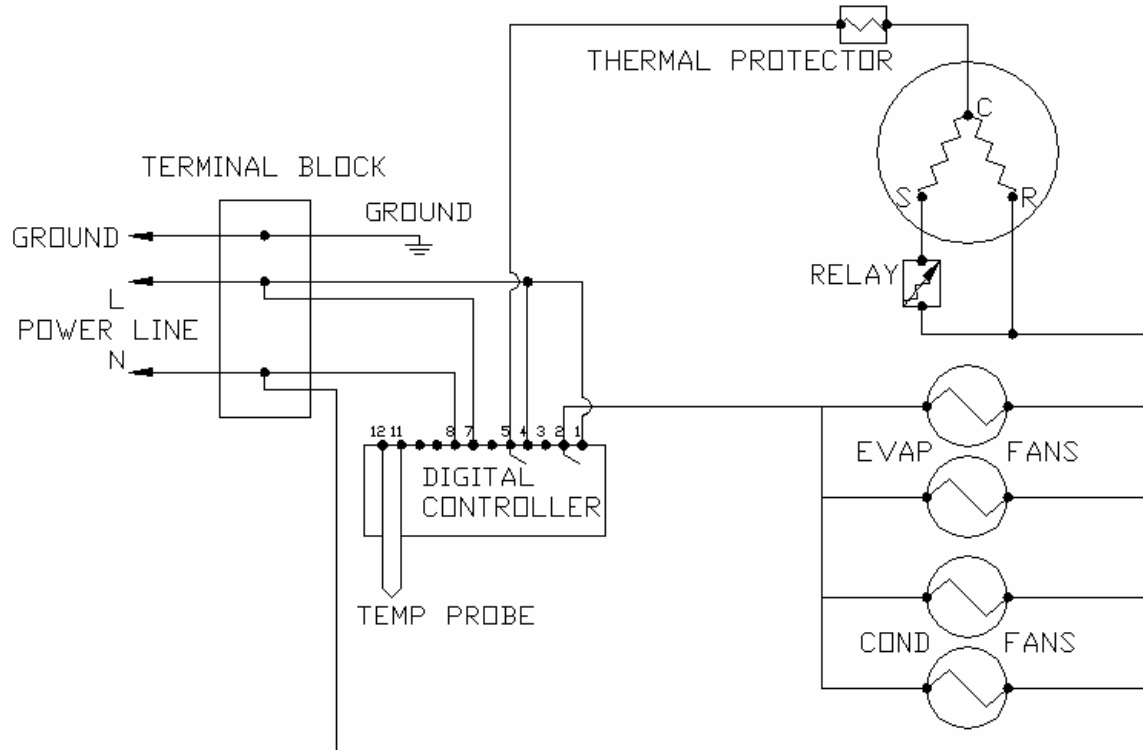

Customer Support

If you still have problems, please contact us at:

Vinotemp International
17631 South Susana Road
Rancho Dominguez, CA 90221
Tel: (310) 886-3332
Fax: (310) 886-3310
Email: info@vinotemp.com

Warranty

Thank you for choosing a Vinotemp wine cellar.

Please enter the complete model and serial numbers in the space provided:

Model _____
Serial No. _____

Attach your purchase receipt to this owner's manual.

1. Limited Warranty

VINOTEMP warrants its products to be free from defects due to workmanship or materials under normal use and service, for twelve months after the initial sale. If the product is defective due to workmanship or materials, is removed within twelve months of the initial sale and is returned to VINOTEMP, in the original shipping carton, shipping prepaid, VINOTEMP will at its option, repair or replace the product free of charge. Additionally VINOTEMP warrants all parts to be free from defects for a period of sixty months after initial sale.

This warranty constitutes the entire warranty of the VINOTEMP with respect to its products and is in lieu of all other warranties, express or implied, including any of fitness for a particular purpose. In no event shall VINOTEMP be responsible for any consequential damages what is so ever. Any modification or unauthorized repair of VINOTEMP products shall void this warranty.

Service under Warranty

This service is provided to customers within the continental UNITED STATES only. VINOTEMP cooling units are warranted to produce the stated number of BTU/H. While every effort has been made to provide accurate guidelines, VINOTEMP can not warranty its units to cool a particular enclosure.

In case of failure, VINOTEMP cooling units must be repaired by the factory or its authorized agent. Repairs or modifications made by anyone else will void the warranty.

Should a VINOTEMP cooling unit fail, contact the dealer for instructions. Do not return the unit to the factory without authorization from VINOTEMP. If the unit requires repair, re-pack it in the original shipping carton and return it to the factory, shipping prepaid. VINOTEMP will not accept COD shipments. If the unit

is determined to be faulty and is within the twelve month warranty period VINOTEMP will, at its discretion, repair or replace the unit and return it free of charge to the original retail customer. If the unit is found to be in good working order, or beyond the initial twelve month period, it will be returned freight collect.

2. Limitation of Implied Warranty

VINOTEMP'S SOLE LIABILITY FOR ANY DEFECTIVE PRODUCT IS LIMITED TO, AT OUR OPTION, REPAIRING OR REPLACING OF UNIT.

**VINOTEMP SHALL NOT BE LIABLE FOR:
DAMAGE TO OTHER PROPERTY CAUSED BY ANY DEFECTS IN THE UNIT,
DAMAGES BASED UPON INCONVENIENCE, LOSS OF USE OF THE UNIT,
LOSS OF TIME OR COMMERCIAL LOSS, ANY OUTER DAMAGES,
WHETHER INCIDENTAL, CONSEQUENTIAL OR OTHERWISE.**

**THIS WARRANTY IS EXCLUSIBE AND IS IN LIEU OF ALL OTHER
WARRANTIES, EXPRESSED OR INPLIED, INCLUDING BUT NOT LIMITED
TO, IMPLIED WARRANTIES OF MERCHANTABILITY OR FITNESS FOR A
PARTICULAR PURPOSE.**

While great effort has been made to provide accurate guidelines VINOTEMP cannot warrant its units to properly cool a particular enclosure. Customers are cautioned that enclosure construction, unit location and many other factors can affect the operation and performance of the unit. There for suitability of the unit for a specific enclosure or application must be determined by the customer and cannot be warranted by VINOTEMP.

Appendix

I. Enclosure

This is only a guide and should be considered as minimum requirements. All interior walls and floors should have a vapor barrier and a minimum of R11 insulation. All exterior walls and ceiling should have a vapor barrier and a minimum of R19 insulation. The vapor barrier should be installed on the warm side of the insulation. There should be no glass doors. All joints, door frames, electrical outlets or switches and any pipes or vents that go through the enclosure should be sealed to prevent air and moisture leakage into the room. Concrete, rock, and brick are not insulation or vapor barriers.

Doors should be of a minimum size, insulated to at least R11 and tightly sealed with high quality weather stripping. Be sure to seal the bottom of the door and fill gap between the door's frame and wall before installing the cap molding. Lighting should be of low wattage, with a timer to insure lights are not left on when the enclosure is not occupied. Recessed lighting should not be used as it will allow outside air to enter the enclosure.

The ambient temperature surrounding the enclosure should not exceed the temperature of the cellar by more than 25 °F. No enclosure wall should receive direct sun or strong wind. Proper sealing of the enclosure through the use of a vapor barrier and weather stripping cannot be over emphasized.

The cooling system will not be able to maintain the proper conditions if fresh moisture-laden air is constantly being introduced to the enclosure. Symptoms of this condition are; unit runs all the time with only a slight reduction in temperature and/or water overflows from the unit. One way of discovering gross air leaks is to stand inside the enclosure with the lights off, allow your eyes to adapt to the dark and look for light showing through cracks in the walls or around the door. Because of the temperature difference between the inside and outside, very small cracks can allow large amounts of outside air to enter into the enclosure. Please be aware that moisture can pass through solid concrete, paint and wood. Often a newly constructed room contains fresh wood, paint, concrete and other building materials. These materials contain large amounts of moisture. When placed into operation in this type of environment, the system will work harder to remove this extra moisture resulting in increased "run" time.

In areas where the relative humidity is very low, the desired humidity may not be achieved without adding moisture. To add moisture, use only slow, natural evaporation from a small water container using distilled water. Do not use a humidifier.