

1224DWR

24" Solid Refrigerator Drawers • 1000 Series



STAINLESS
SOLID



INTEGRATED
SOLID

FEATURES & BENEFITS

PERFORMANCE	<ul style="list-style-type: none"> • Volume of 5.4 cu ft holds up to 98 bottles (12 oz) or 150 cans (12 oz) • Digital Touch Pad Control is conveniently located in top drawer • Temperature range: 34°F - 45°F • Digital passive cooling system • Maintains temperature to within 1°F of the set point to maximize preservation
INTERIOR/EXTERIOR	<ul style="list-style-type: none"> • Black interior is illuminated with LED lighting • Equipped with 2 full-extension robust stainless drawers • Standard commercial stainless steel handle is interchangeable with professional handle accessory
INTEGRATION	<ul style="list-style-type: none"> • Unit is designed to be built-in or can be freestanding with the freestanding accessory kit • Integrated model requires ¾" custom door panel • Four independently adjustable leveling legs provide a precise undercounter fit • Available in the following finishes: Stainless or Integrated

MODEL DETAILS

Model	Voltage	Door Swing	Finish	Shipping Weight
U-1224DWRS-00A	115	Drawers	Stainless Solid	142 lbs
U-1224DWRINT-00A	115	Drawers	Integrated Solid	134 lbs

ACCESSORIES

Model	Description	Finish	Shipping Weight
23054	Professional Door Handle, 1 ¼" Diameter	Stainless	2 lbs
U-FSK-B	Freestanding Kit	Black	3 lbs

DIMENSIONS

Dimensions shown apply to all finishes, including Integrated (INT) models with 3/4" overlay panel/frame installed.

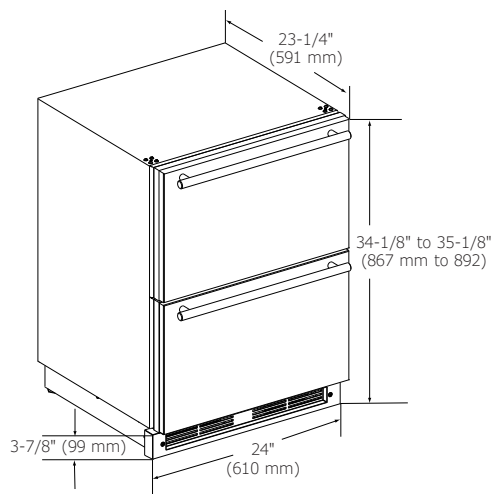

CABINET CUT-OUT

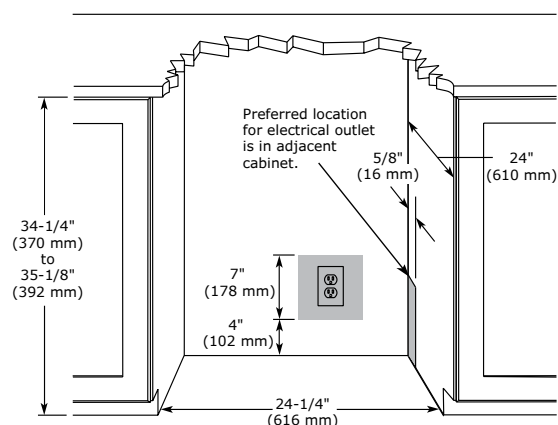

INSTALLATION NOTES

Cutout includes the additional 1/4" width overall to ensure proper installation.

No additional clearance around sides, top or rear of unit is needed for ventilation.

SPECIFICATIONS

Model	1224DWR
Amps: Running	1.2
Capacity: Bottle (12 oz)	98
Capacity: Can (12 oz)	150
Capacity: Volume (cu ft)	5.4
Control Type	Digital Touch Pad
Dimensions: Product Depth	23 1/4" / 591 mm
Dimensions: Product Height	34 1/8" / 867 mm
Dimensions: Product Width	24" / 610 mm
Energy Consumption: Avg. Per Year	305 kWh
ENERGY STAR	No
Product Weight: Max	132 lbs
Refrigerant Type	R600a
Sabbath (Star K Certified)	Yes
Temperature Range	34°F - 45°F

COOLING SYSTEM

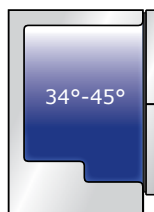

ELECTRICAL REQUIREMENTS

This unit requires a grounded a polarized 115 VAC, 60 Hz, 15 A power supply (normal household current).

Please visit u-line.com to view this model's User Guide. All specifications are subject to change without notice.



Residential & Commercial