

1224R • 24" Solid Door Refrigerator • 1000 Series

FEATURES & BENEFITS



STAINLESS SOLID



INTEGRATED SOLID



BLACK SOLID



WHITE SOLID

PERFORMANCE	<ul style="list-style-type: none"> • Volume of 5.2 cu ft holds up to 123 bottles (12 oz) or 185 cans (12 oz) • Digital Touch Pad Control is conveniently located on upper face of unit • Temperature range: 34°F - 45°F • Maintains temperature to within 1°F of the set point to maximize preservation
INTERIOR/EXTERIOR	<ul style="list-style-type: none"> • White interior is illuminated with LED lighting • Three removable tempered glass shelves • Standard commercial stainless steel handle is interchangeable with professional handle accessory • Door swing is field reversible
INTEGRATION	<ul style="list-style-type: none"> • Unit is designed to be built-in or can be freestanding with the freestanding accessory kit • Integrated model requires 3/4" custom door panel (panels not supplied by U-Line) • Four independently adjustable leveling legs provide a precise undercounter fit • Available in the following finishes: Stainless, Integrated, Black, or White

MODEL DETAILS

Model	Voltage/Hz	Door Swing	Finish	Shipping Weight
U-1224RS-00A	115 / 60	Field Reversible	Stainless Solid	109 lbs
U-1224RINT-00A	115 / 60	Field Reversible	Integrated Solid	106 lbs
U-1224RB-00A	115 / 60	Field Reversible	Black Solid	109 lbs
U-1224RW-00A	115 / 60	Field Reversible	White Solid	109 lbs

ACCESSORIES

Model	Description	Finish	Shipping Weight
23074	Professional Door Handle, 1 1/4" Diameter	Stainless	2 lbs
23073	Commercial Door Handle, 7/8" Diameter	Stainless	2 lbs
U-FSK-B	Freestanding Kit	Black	3 lbs

1000 Series • 24" Solid Door Refrigerator • 1224R

DIMENSIONS

Dimensions shown apply to all finishes, including Integrated (INT) models with 3/4" integrated panel/frame installed.

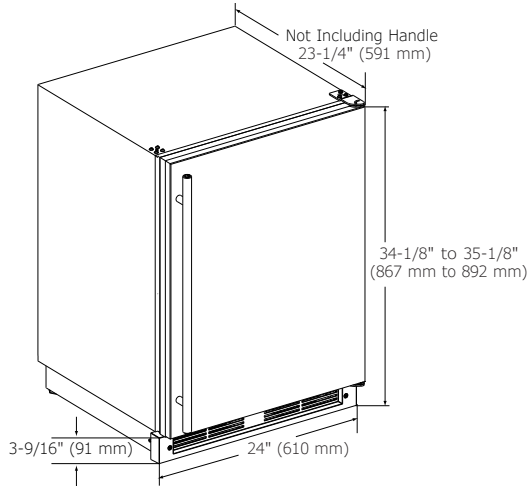

CABINET CUT-OUT

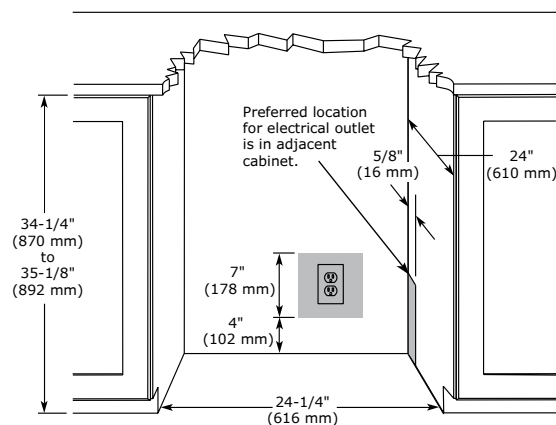

INSTALLATION NOTES

When installing adjacent to wall, ensure 2 1/2" clearance on hinged side for 90° door opening, allowing ample room for door handle.

Cutout includes the additional 1/4" width overall to ensure proper installation.

No additional clearance around sides, top or rear of unit is needed for ventilation.

Do not obstruct front grille air flow.

SPECIFICATIONS

Model	1224R
Amps: Running	1.2
Capacity: Bottle (12 oz)	123
Capacity: Can (12 oz)	185
Capacity: Volume (cu ft)	5.2
Control Type	Digital Touch Pad
Dimensions: Product Depth	23 3/4" / 591 mm
Dimensions: Product Height	34 1/8" / 867 mm
Dimensions: Product Width	24" / 610 mm
Energy Consumption: Avg. Per Year	240 kWh
ENERGY STAR / CEE RATING	ENERGY STAR / Tier 3
Panel Height	30 1/4" / 768 mm
Panel Thickness	3/4" / 20 mm
Panel Type	Solid Panel
Panel Width	23 3/4" / 603 mm
Product Weight: Max	99 lbs
Refrigerant Type	R600a
Sabbath (Star K Certified)	Yes
Temperature Range	34°F - 45°F

COOLING SYSTEM



ELECTRICAL REQUIREMENTS

This unit requires a grounded a polarized 115 VAC, 60 Hz, 15 A power supply (normal household current).

Please visit u-line.com to view this model's User Guide. All specifications are subject to change without notice.



Residential & Commercial