

BI1215 • 15" Crescent Ice Maker • 1000 Series

FEATURES & BENEFITS



STAINLESS SOLID



INTEGRATED SOLID



BLACK SOLID



WHITE SOLID

PERFORMANCE	<ul style="list-style-type: none"> • Uses less than 3 gallons of water to produce up to 25 lbs of ice per day • Up to 25 lbs in ice storage capacity • Daily ice production rate is approx. 4 times greater than the average household refrigerator • Crescent ice cube dimensions: 1/2" W x 3/4" H x 1/2" L • On/Off switch is conveniently located on lower face of unit
INTERIOR/EXTERIOR	<ul style="list-style-type: none"> • No drain required • Standard commercial stainless steel handle is interchangeable with professional handle accessory • Door swing is field reversible
INTEGRATION	<ul style="list-style-type: none"> • Unit is designed to be built-in or can be freestanding • Integrated model requires 3/4" custom door panel (panels not supplied by U-Line) • Four independently adjustable leveling legs provide a precise undercounter fit • Available in the following finishes: Stainless, Integrated, Black, or White

MODEL DETAILS

Model	Voltage/Hz	Door Swing	Finish	Shipping Weight
U-BI1215S-00A	115 / 60	Field Reversible	Stainless Solid	89 lbs
U-BI1215INT-00A	115 / 60	Field Reversible	Integrated Solid	89 lbs
U-BI1215B-00A	115 / 60	Field Reversible	Black Solid	89 lbs
U-BI1215W-00A	115 / 60	Field Reversible	White Solid	89 lbs

ACCESSORIES

Model	Description	Finish	Shipping Weight
23074	Professional Door Handle, 1 1/4" Diameter	Stainless	2 lbs
23073	Commercial Door Handle, 7/8" Diameter	Stainless	2 lbs
WATERHOOKUP	Braided water supply line kit	na	2 lbs

1000 Series • 15" Crescent Ice Maker • **BI1215**

DIMENSIONS

Dimensions shown apply to all finishes, including Integrated (INT) models with 3/4" integrated panel/frame installed.

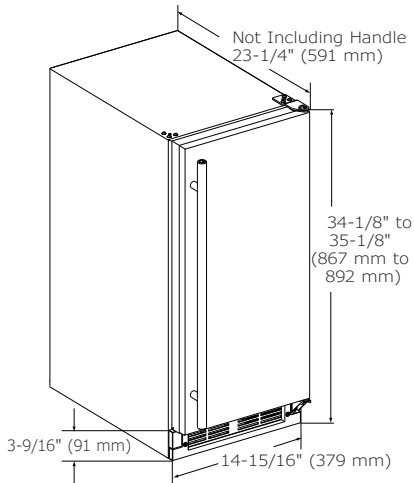

CABINET CUT-OUT

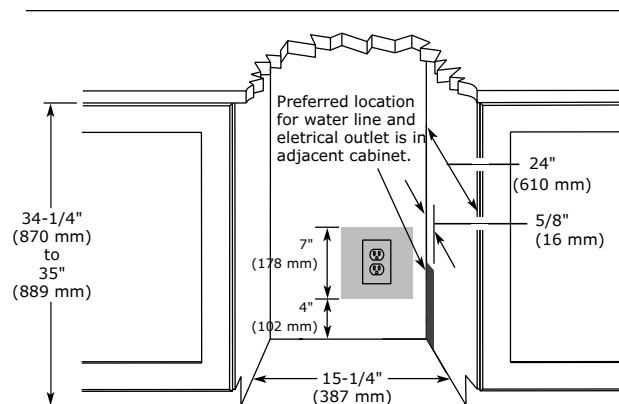

SPECIFICATIONS

Model	BI1215
Amps: Running	2.5
Control Type	On/Off Switch
Defrost Type	Manual
Dimensions: Product Depth	23 1/4" / 591 mm
Dimensions: Product Height	34 1/8" / 867 mm
Dimensions: Product Width	14 15/16" / 379 mm
Energy Consumption: Avg. Per Year	na
ENERGY STAR	na
Ice Production Per Day	25 lbs
Ice Storage	25 lbs
Panel Height	30 1/4" / 768 mm
Panel Thickness	3/4" / 20 mm
Panel Type	Solid Panel
Panel Width	14 3/4" / 375 mm
Product Weight: Max	83 lbs
Refrigerant Type	R134a
Sabbath (Star K Certified)	No

INSTALLATION NOTES

- When installing adjacent to wall, ensure 2 1/2" clearance on hinged side for 90° door opening, allowing ample room for door handle.
- No additional clearance around sides, top or rear of unit is needed for ventilation.
- Do not obstruct front grille air flow.

ELECTRICAL REQUIREMENTS

This unit requires a grounded a polarized 115 VAC, 60 Hz, 15 A power supply (normal household current).



Please visit u-line.com to view this model's User Guide. All specifications are subject to change without notice.