

**CO29F • 21" ADA Combo® Model • ADA Series**

**FEATURES & BENEFITS**



BLACK  
SOLID



WHITE  
SOLID

<b>PERFORMANCE</b>	<ul style="list-style-type: none"> <li>• Refrigerator volume of 2.1 cu ft holds up to 24 bottles (12 oz) or 44 cans (12 oz)</li> <li>• Mechanical Dial Control is conveniently located on the grille</li> <li>• Temperature range: 34°F - 45°F</li> <li>• Mechanical passive cooling system</li> <li>• Produces and stores up to 8 lbs of ice per day</li> <li>• Crescent ice cube dimensions: 1/2" W x 3/4" H x 1/2" L</li> </ul>
<b>INTERIOR/EXTERIOR</b>	<ul style="list-style-type: none"> <li>• No drain required</li> <li>• Two removable tempered glass shelves</li> <li>• Two fixed storage compartments in door</li> <li>• Door swing is field reversible</li> </ul>
<b>INTEGRATION</b>	<ul style="list-style-type: none"> <li>• Unit is designed to be built-in or can be freestanding</li> <li>• Accepts a 1/4" custom insert panel</li> <li>• Available in the following finishes: Black or White</li> </ul>

**MODEL DETAILS**

Model	Voltage/Hz	Door Swing	Finish	Shipping Weight
U-CO29FB-00A	115 / 60	Field Reversible	Black Solid	101 lbs
U-CO29FW-00A	115 / 60	Field Reversible	White Solid	101 lbs

**ACCESSORIES**

Model	Description	Finish	Shipping Weight
WATERHOOKUP	Braided water supply line kit	na	2 lbs

ADA Series • 21" ADA Combo® Model • C029F

**DIMENSIONS**

Dimensions shown apply to all finishes, including Integrated (INT) models with 3/4" integrated panel/frame installed.

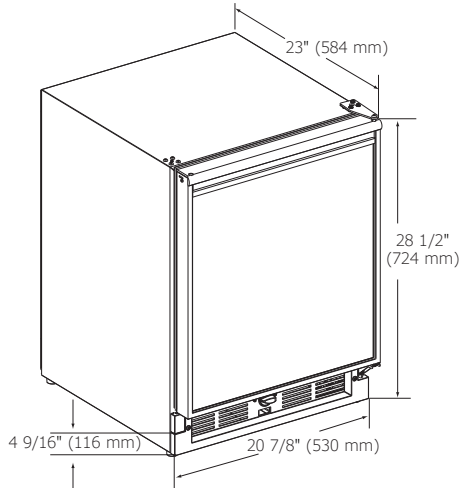

**CABINET CUT-OUT**

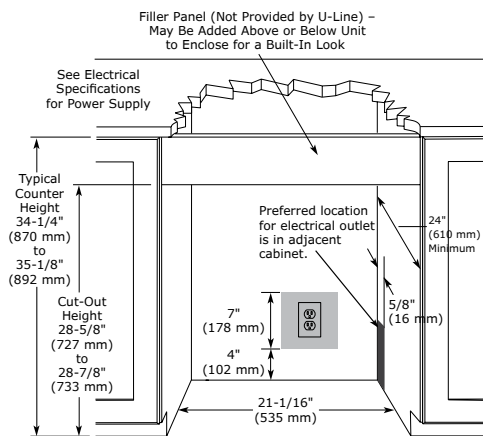

**INSTALLATION NOTES**

- Cutout includes the additional 1/4" width overall to ensure proper installation.
- When installing a left-hand hinge model, allow for 145° door swing for proper removal of ice bin.
- No additional clearance around sides, top or rear of unit is needed for ventilation.
- Do not obstruct front grille air flow.

**SPECIFICATIONS**

Model	C029F
Amps: Running	2.5
Capacity: Bottle (12 oz)	24
Capacity: Can (12 oz)	44
Capacity: Refrigerator Volume (cu ft)	2.1
Control Type	Mechanical Dial
Defrost Type	Frost Free
Dimensions: Product Depth	23" / 584 mm
Dimensions: Product Height	28 1/2" / 724 mm
Dimensions: Product Width	20 7/8" / 530 mm
Energy Consumption: Avg. Per Year	567 kWh
ENERGY STAR	No
Ice Production Per Day	8 lbs
Ice Storage	8 lbs
Product Weight: Max	92 lbs
Refrigerant Type	R134A
Sabbath (Star K Certified)	No
Temperature Range	34°F - 45°F

Please visit [u-line.com](http://u-line.com) to view this model's User Guide. All specifications are subject to change without notice.

