



Kegco

INSTRUCTION MANUAL

MINI REFRIGERATOR

MODEL: HK-46-SD



BEFORE USE, PLEASE READ AND FOLLOW ALL SAFETY RULES AND OPERATING INSTRUCTIONS.

Kegco has a policy of continuous improvement on its products and reserves the right to change materials and specifications without notice

KEGCO

8520 Miralani Dr., San Diego, CA 92126

Table of Contents

Diagram and Description	3
Safety Tips	4
Installation Instructions	5
Reversing the Door	6
Setting Temperature	7
Care and Maintenance	8
Troubleshooting	9
Technical Specifications	10
Energy Guide	12
Warranty Information	13

Diagram and Description

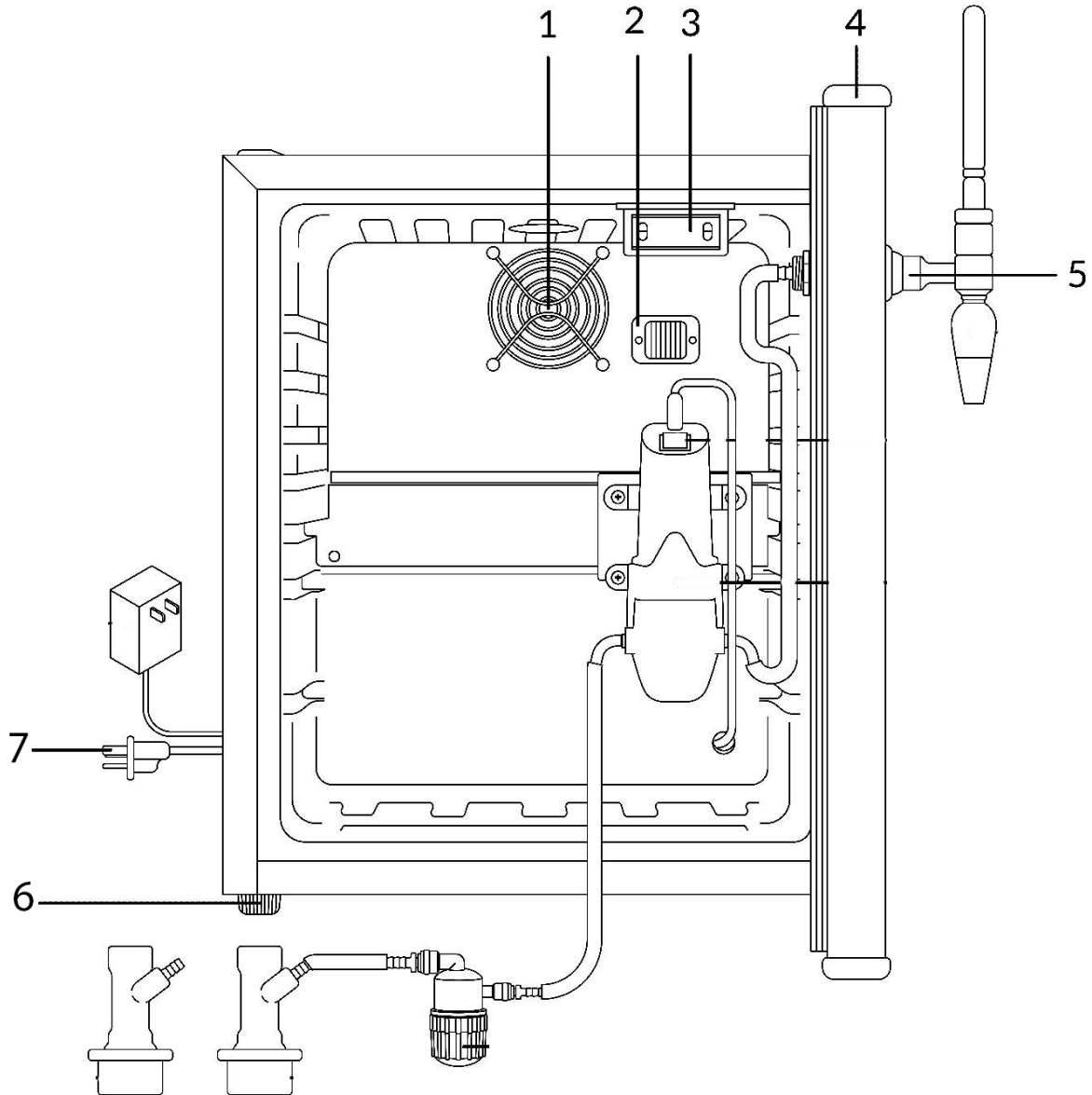

1. Fan
2. Temperature Sensor
3. Temperature Control
4. Door
5. Shank
6. Foot
7. Refrigerator Power Cord

Safety Tips

Before using this appliance, it must be properly positioned and installed as described in this manual, so please read the manual carefully. To reduce the risk of fire, electrical shock or injury when using the appliance, follow these basic precautions. Failure to heed these safety requirements may result in severe personal injury or death.

DANGER

- Plug into a grounded 3-prong outlet. Do not under any circumstances cut or remove the third ground prong from the power cord supplied, do not use an adapter, and do not use an extension cord.
- It is recommended that a separate circuit, serving only your appliance be used. Do not use outlets that can be turned off by a switch or pull chain.
- Never clean appliance parts with flammable fluids and do not store or use gasoline or other flammable vapors and liquids in the vicinity of this or any other appliance. The fumes can create a fire hazard or explosion.
- Unplug the appliance or disconnect power before cleaning or servicing. Failure to do so can result in electrical shock or death.
- Do not attempt to repair or replace any part of your appliance unless it is specifically recommended in this manual. All other servicing should be referred to a qualified technician.
- Caution! Risk of fire or explosion. Flammable refrigerant used. Isobutane (R600a) is a gas with a high level of environmental compatibility but is nevertheless flammable. Follow handling instructions carefully. The appliance must be installed in a space that is at least 1 cubic meter per 8g of refrigerant. All safety precautions must be followed when servicing the unit. Dispose of properly in accordance with federal or local regulations.

WARNING

- To ensure proper ventilation for your appliance, the front of the unit must be completely unobstructed. Choose a well-ventilated area that is protected from the elements, such as wind, rain, water spray or drips.
- The appliance should not be located next to ovens, grills or other high heat sources or in areas of extreme cold.
- The appliance must be installed in accordance with state and local codes. A standard electrical supply (115 V AC only, 60 Hz), properly grounded in accordance with the National Electrical Code and local ordinances is required.
- Do not kink or pinch the power supply cord of appliance.
- The fuse (or circuit breaker) size should be 15 amperes.
- It is important for the appliance to be leveled in order to work properly.
- Never allow children to operate or play with the appliance.
- Do not use solvent-based cleansers or abrasives on the interior as they may damage or discolor the interior.
- Because of potential safety hazards under certain conditions, it is strongly recommended that you do not use an extension cord with this appliance. However, if you must use an extension cord, it is absolutely necessary that it be a UL/CUL-Listed, 3-wire grounding type appliance extension cord having a grounding type plug and outlet and that the electrical rating of the cord be 115 volts and at least 10 amperes.
- It is suggested that you use a power surge protector. The surge protector that you select must have a surge block high enough to protect the appliance it is connected to. Damages due to power surges are not considered a manufacturer covered defect and will void your product warranty.
- The cord should be secured behind the appliance and not left exposed or dangling to prevent accidental injury. Never unplug the appliance by pulling the power cord. Always grip the plug firmly and pull straight out from the receptacle. Repair or replace immediately all power cords that have become frayed or otherwise damaged. Do not use a cord with cracks or abrasion damage along its length or at either end. When moving the appliance, be careful not to damage the power cord.
- Do not use this apparatus for other than its intended purpose.
- **California Proposition 65 Warning:** This product can expose you to Styrene/Nickel, which are known to the state of California to cause cancer. For more information go to: www.P65Warnings.ca.gov

Failure to heed these safety warnings may result in extensive product damage, serious personal injury, or death.

Installation Instructions

BEFORE USE:

- Remove the exterior and interior packaging.
- Before connecting the unit to the power source, let it stand upright for approximately 24 hours. This will reduce the possibility of a malfunction in the cooling system from handling during transportation.
- Clean the interior surface with lukewarm water using a soft cloth.
- This appliance is designed for freestanding use. A space of at least 3" should be allowed between the surrounding walls and the cabinet wall for air circulation.
- Place the unit on a flat, solid floor that is strong enough to support it when it is fully loaded.
- If the refrigerator is to be placed on carpet, support it with a wooden board underneath. Be aware that placing the refrigerator on carpet may mean that heat from the compressor may cause the carpet to fade.
- When moving your refrigerator, please do not incline it more than 45 degrees.
- Locate the appliance away from direct sunlight and sources of heat (stove, heater, radiator, etc.). Direct sunlight may affect the acrylic coating and heat sources may increase electrical consumption.
- The refrigerator should be placed in an area where the ambient temperature is less than 90 degrees Fahrenheit and higher than the lowest temperature you want to store your beverages at. If the ambient temperature is lower than the set temperature, the internal temperature will match the ambient temperature.
- Install the unit in a dry place to prevent rust from forming on the compartment body, which may affect the electrical insulation.
- Plug the cooler into an exclusive, properly installed and grounded wall outlet. Do not under any circumstances cut or remove the third (ground) prong from the power cord. Any questions concerning power and/or electrical grounding should be directed to a certified electrician or authorized products service center.
- After plugging the appliance into a wall outlet, allow the unit to cool down for 3 to 4 hours before stocking it with beverages.

1-888-980-4810

Reversing the Door

You will need to tilt the fridge backwards to access the lower hinge that holds the screws. Do not tilt the appliance more than 45 degrees and do not lay it flat on its side.

1. Remove the top plastic hinge cover and set aside.



2. Unscrew the 3 screws from the metal bracket and set aside. Then, carefully remove the door and place it on a cushioned surface.

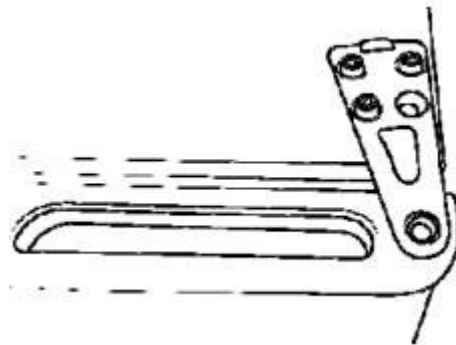

3. Remove the plastic insert on the opposite side of the fridge and door. Then, attach the top door bracket to this side using the screws that were previously removed. Replace the plastic hinge cover.

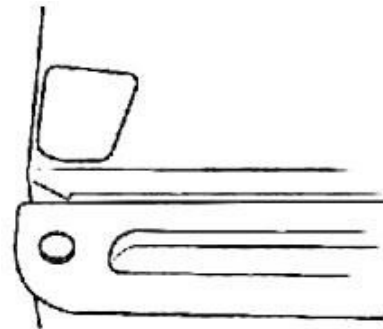

4. Remove the adjustable foot at the bottom of the fridge and set aside.

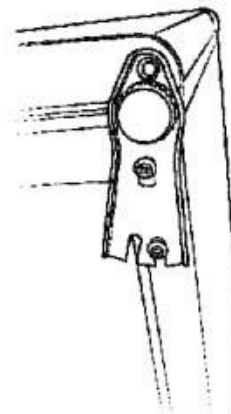

5. Unscrew the two screws holding the bottom door hinge and carefully move it across to the opposite side. Before fixing it into position, fit the door to the top and bottom hinge, taking care as the door will be loose. Then, screw in the adjustable foot on the opposite side of the fridge.



Check that the door opens and closes properly after you have completed the door reversal process. Wait until the appliance has been upright for a minimum of 3 hours before turning it on.



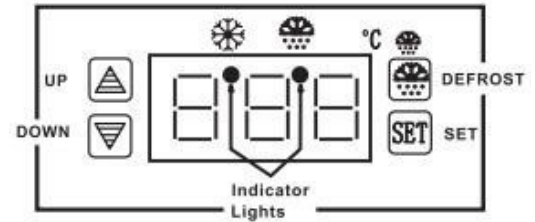

Using the Electronic Controls

The electronic control panel is located on the inside back wall of the unit.

During normal operation, the controller display  will show the temperature inside of the refrigerator. A small indicator light will illuminate under the cooling symbol  to indicate that the fridge is in its normal cooling mode and that the compressor is running. When the set temperature has been reached and the compressor is in its "off" cycle, no indicator lights will be illuminated .



SETTING TEMPERATURE:



- Press the  button once. A beep will sound and the display will start to flash.
- Use the   buttons to set the desired temperature.
- Press  again to immediately complete the operation. If you do not press , after 5-10 seconds the new settings will automatically save and the display will revert to showing the internal temperature.

NOTE: The fridge is built to automatically defrost and prevent any ice from forming on the evaporator. When in a defrost cycle, the indicator light will illuminate under the defrost symbol.

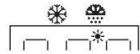
MANUALLY ACTIVATING DEFROST CYCLE:

- Press and hold the  button for 6 seconds, until you hear a beep.
- The indicator light will be illuminated under the defrost symbol, indicating that the fridge is now in a defrost cycle. 
- The defrost cycle will run for 20 minutes, and then will automatically revert to normal operation.

RESUMING NORMAL OPERATION AFTER MANUAL DEFROST:

- Press and hold the  button again for 6 seconds, until a beep is heard.
- Both indicator lights under the defrost and cooling symbols will flash  while the fridge is gearing up to switch back to normal operation.
- After 5-20 minutes, only the indicator light under the cooling symbol will be illuminated , indicating that the fridge has returned to its normal cooling mode.

ENERGY SAVING TIPS:

- Place the fridge in the coolest area of the room, away from heat-producing appliances and out of direct sunlight.
- Let hot items cool to room temperature before placing them into the fridge.
- Wipe items dry before placing them in the fridge. This cuts down on frost buildup inside of the cooler.
- Do not leave the fridge door open for longer than necessary.
- Make sure nothing touches the back of the compartment.
- Do not set the thermostat to extremely cold temperatures.

Care and Maintenance

Disconnect the appliance from the power source before cleaning. When you have finished cleaning, reconnect the plug with dry hands.

INTERNAL CLEANING OF THE CABINET:

- Do not pour water over the appliance.
- The cooler interior should be cleaned periodically using a solution of baking soda and lukewarm water (5 ml to 0.5 liter of water).
- Do not use abrasive products, detergents, or soaps.
- After washing, rinse with clean water and dry carefully.

EXTERNAL CLEANING OF THE CABINET:

- Wash the outer cabinet with warm soapy water. Do not use abrasive products.
- There are sharp edges on the underside of the product, so care should be taken when cleaning.
- Once or twice a year, dust the back of the appliance with a brush or vacuum cleaner, as an accumulation of dust will affect the performance of the appliance and cause increased energy consumption.

WARNING:

1. Never clean the unit with an abrasive, acid, oil, or solvent based cleaning agent, or with abrasive pads or scourers. Never use flammable fluids or sprays for cleaning as the fumes from these substances can create a fire hazard or explosion.
2. Never clean the appliance with a steam cleaner. Moisture could accumulate in the electrical components, creating the risk of an electric shock. Hot vapors can lead to damage to the plastic parts.
3. The appliance must be completely dry before it is placed back into service.
4. Ethereal oils and organic solvents (like lemon juice, orange peel juice, or cleansers that contain acetic acid) can attack plastic parts. Do not allow such substances to come into contact with the appliance parts.

DEFROSTING:

The surface of the evaporator ices up when the refrigerator is working. This is an entirely normal part of operation. If the frost layer is more than 1/8" thick, the refrigerator must be defrosted and cleaned to avoid unnecessary energy consumption and inefficient operation.

- Remove all items inside and unplug the refrigerator.
- After defrosting, clean the refrigerator and allow it to dry.
- Reconnect to the power supply and run the refrigerator.

Troubleshooting

There are many common issues you may experience with your cooler that can be solved very easily, without the need of a service call. Try the tips below to troubleshoot your unit should you experience any problems:

PROBLEM	POSSIBLE CAUSE
Smell/odor	Contents are out of date or incorrectly packaged. Spillage has occurred.
Doors do not close properly	Obstructions are preventing door closure. Door seal is warped or torn. Appliance is not level.
Unusual noises	Appliance is not on a flat, level surface and is not stable. There is not sufficient spacing around the appliance and the appliance is touching other items. Bubbling and gurgling noises are normal, and are emitted as the coolant fluid flows through the pipes within the system. Water flowing sounds are normal, and occur when water flows into the drain trough during the defrosting process. Compressor noise is normal, and indicates that it is operating properly. As the compressor is being energized, it might run a bit more noisily for a short period of time. Contraction and expansion of the inside walls may cause popping and cracking noises.
Fridge door will not open	If the door has just been opened, leave it for a few minutes to allow the air pressure to equalize before trying again.
Compressor runs continuously	Temperature is set too cold; select a warmer setting. Door is open, or something is obstructing door closure. Door gaskets are worn, dirty, or damaged. A large number of items have been added to the fridge. Room temperature is hotter than usual.
External fridge surface is warm	Exterior walls can be warmer than room temperature when the compressor works to transfer heat from inside the fridge cabinet; this is normal.
Fridge doesn't work	Appliance is not switched on. There has been a power cut. Plug is faulty. Fuse has blown. Voltage is not correct for the appliance. There may be faults with the socket; to test, try the appliance's plug by connecting it to a socket that you are sure is working.
Temperature inside of the cabinet is not cold enough	The appliance is too full. Thermostat is not set to a suitable temperature. Appliance has been placed in direct sunlight or too close to a heating source. Ambient temperature is outside of the operation limits of the appliance. Appliance door is opened too frequently in humid conditions, causing a buildup of moisture. Door is not closed completely. Door gasket does not seal properly. Cooler does not have the proper clearances at the sides/back.
Moisture has formed on the inside or outside walls of the fridge	Hot or humid weather increased the internal rate of frost build-up; this is normal. Open the door less often and make sure it is always properly closed.
Outer surfaces of the appliance are wet	Condensation will form on the outside of the cooler if it operates in moist areas; simply wipe it dry.

Technical Specifications

Capacity	2.5 Gallon Kegco Strap Handle Ball Lock Keg
Dimensions	20.3" H x 16.9" W x 19.5" D
Cubic Footage	1.34 Cubic Feet
Weight	34 lbs.
Voltage / Frequency	110V/60Hz
Running Amps	1.3A
Wattage	143 watts
Refrigerant	600a
Temperature Range	32 to 50 degrees Fahrenheit



CONFORMS TO UL STD.471
 CERTIFIED TO CSA STD.C22.2 NO.120
 CONFORMS TO NSF STD.18



Mini Refrigerator

MODEL	HK-46-SD
STORAGE VOLUME	1.34cu.ft
VOLTAGE	110V/60Hz
TOTAL AMPS	1.3A
REFRIGERANT	R600a/0.53oz
DIMENSIONS (HxWxD)	20.3x16.9x19.5 inch
HIGH PRESSURE TEST	220 PSI
LOW PRESSURE TEST	43 PSI
SERIAL NO.82	

CIRCUIT DIAGRAM

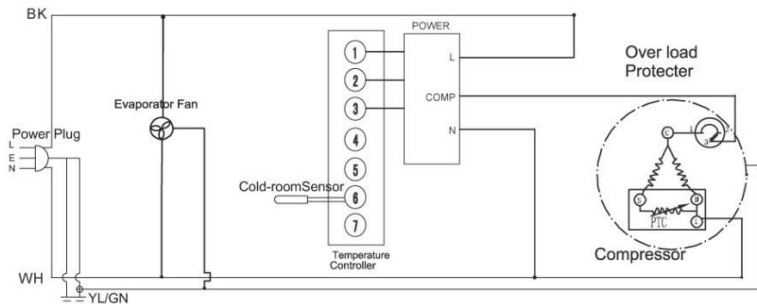

U.S. Government

Federal law prohibits removal of this label before consumer purchase.

ENERGYGUIDE

Refrigerator

- Automatic Defrost



Cydea.dba beverage factory

Model(s):HK-46-SD

Capacity:1.34 Cubic Feet

Compare ONLY to other labels with yellow numbers.
Labels with yellow numbers are based on the same test procedures.

Estimated Yearly Energy Cost

\$26



Cost range not available

219 kWh

Estimated Yearly Electricity Use

- Your cost will depend on your utility rates and use.
- Cost range based only on models of similar capacity with automatic defrost.
- Estimated energy cost based on a national average electricity cost of 12 cents per kWh.

ftc.gov/energy

Warranty Information

WHAT IS COVERED LIMITED ONE-YEAR WARRANTY:

For one year from the date of purchase by the original owner, Kegco will, at its option, repair or replace any part of the unit, which proves to be defective in material or workmanship under normal use. During this period Kegco will provide all parts and labor necessary to correct such defects free of charge, so long as the unit has been installed and operated in accordance with the written instructions in this manual. Kegco will provide you with a reasonably similar replacement product that is either new or factory refurbished. In rental or commercial use, the warranty period is 90 days. All Kegco Appliances of 3.5 cubic feet capacity or less must be brought/sent to the appliance service shop for repair.

LIMITED SECOND THROUGH FIFTH YEAR WARRANTY:

For the second through the fifth year from date of original purchase, Kegco Products will provide a replacement compressor free of charge due to a failure. You are responsible for the service labor and freight charges. In rental or commercial use, the limited compressor warranty is one year and nine months. Cost to move the appliance to the servicers' shop and back to the user's home, as may be required, are the user's responsibility.

WHAT IS NOT COVERED:

- Content losses of food or other, due to spoilage.
- Incidental or consequential damages.
- Parts and labor costs for the following will not be considered as warranty:
 - Door springs, and/or frames.
 - Inner door panels, door rails and/or door supports.
 - Light bulbs and/or plastic housing.
 - Plastic cabinet liners.
 - Punctured evaporator that voids the warranty on the complete sealed system.
 - Repairs performed by unauthorized servicers.
 - Shipping and handling costs associated with the replacement of the unit.
 - Service calls that do not involve defects in material or workmanship such as customer education, door reversal, or proper installation.
 - Surcharges including, but not limited to, any after hour, weekend, or holiday service calls, tolls, ferry trip charges, or mileage expense for service call to remote areas, including the State of Alaska.
 - Service calls that are related to external problems, such as abuse, misuse, inadequate electrical power, accidents, fire, floods, or acts of God.
 - Replacement of house fuses or resetting circuit breakers.
- Failure of the product if it is used for other than its intended purpose.
- This warranty does not apply outside the Continental USA.

SERVICE FOR YOUR COOLER:

With the purchase of your Kegco appliance, you can have the confidence that if you ever need additional information or assistance, the Kegco Customer Service team will be here for you. Whatever your questions are about our products, help is available. Just call us toll-free.

KEGCO PRODUCT CUSTOMER SERVICES:

Product Information, Part Orders and In-Home Repair Service: **888-980-4810**