



Self-Contained Clear Ice Maker

INSTRUCTION MANUAL



PERLICK RESIDENTIAL UNDERCOUNTER ICE MAKER MODELS

HP15CI-L(-R)(-W) – 15" Signature Series Clear Ice Maker

HA15CI-L(-R)(-W) – 15" ADA Compliant Clear Ice Maker

To prevent appliance damage and injury, read these instructions thoroughly prior to installation.

⚠ WARNING

Only qualified service technicians should install and service the appliance. To obtain the name and phone number of your local Perlick Certified Service Representative, visit www.perlick.com. No installation or service should be undertaken until the technician has thoroughly read this Instruction Manual. Likewise, the owner/manager should not proceed to operate the appliance until the installer has instructed them on its proper operation. Failure to install, operate, and maintain the appliance in accordance with this manual will adversely affect safety, performance, component life, and warranty coverage and may result in costly water damage. Proper installation is the responsibility of the installer. Product failure or property damage due to improper installation is not covered under warranty.

Perlick provides this manual primarily to assist qualified service technicians in the installation, maintenance, and service of the appliance.

WARRANTY REGISTRATION

To register your Perlick appliance, visit our website at www.perlick.com/warranty-and-support and fill out the form. Once completed, click on the 'Submit Warranty Registration'. Be sure to register your appliance immediately upon installation to receive the warranty from installation date instead of shipment date. If left blank, the date will revert back to shipment date.

NOTE: To expedite assistance, all correspondence/communication **MUST** include the following information:

- Model Number _____
- Serial Number _____
- Complete and detailed explanation of the problem.

IMPORTANT

This manual should be read carefully before the appliance is installed and operated. Read the warnings and guidelines contained in this manual carefully as they provide essential information for the continued safe use and maintenance of the appliance. Retain this manual for any further reference that may be necessary.

CONTENTS

Important Safety Information	4
I. Specifications.....	9
A. Construction.....	9
B. Electrical and Refrigerant Data	10
C. Dimensions/Connections	11
1. HP15CI-L(-R)	11
2. HP15CI-W.....	12
3. HA15CI-L(-R).....	13
4. HA15CI-W.....	14
II. Installation Instructions	15
A. Location	15
1. General	15
2. Built-In Installation Site	17
B. Checks Before Installation.....	18
C. HP15CI-W, HA15CI-W Door	19
D. Setup.....	27
E. Electrical Connection	28
F. Water Supply and Drain Connections	29
G. Final Checklist	32
1. Pre-Startup.....	32
2. Post-Startup.....	32
III. Operating Instructions.....	33
A. Important Notes About Usage.....	34
B. Startup and Bin Control Check.....	35
IV. Maintenance	38
A. Maintenance Schedule.....	38
B. Cleaning and Sanitizing Instructions	39
C. Ice Storage Bin Drain	43
D. Drain Pump	43
E. Condenser.....	44
V. Preparing the Appliance for Periods of Non-Use	45
VI. Decommissioning and Disposal	46

Important Safety Information

Throughout this manual, notices appear to bring your attention to situations which could result in death, serious injury, damage to the appliance, or damage to property.

	R-290 Class A3 Flammable Refrigerant Used	
⚠ DANGER	Indicates a hazardous situation that, if not avoided, will result in death or serious injury.	
⚠ WARNING	Indicates a hazardous situation that, if not avoided, could result in death or serious injury.	
NOTICE	Indicates a situation that, if not avoided, could result in damage to the appliance or property.	
IMPORTANT	Indicates important information about the use and care of the appliance.	
⚠ DANGER		
<p><u>Risk of Fire or Explosion</u> <u>Flammable Refrigerant Used</u></p> <ul style="list-style-type: none"> • Only qualified service technicians should install and service the appliance. • No installation, operation, or maintenance should be undertaken until the technician has thoroughly read this Instruction Manual. All safety precautions must be followed. • No service should be undertaken until the technician has thoroughly read the Service Manual available at www.perlick.com. All safety precautions must be followed. • This appliance to be installed in accordance with the Safety Standard for Refrigeration Systems ANSI/ASHRAE 15. • Follow handling instructions carefully in compliance with national regulations. • Do not use mechanical devices or other means to accelerate the defrosting process or to clean, other than those recommended by the manufacturer. • Do not puncture refrigerant tubing. Risk of fire or explosion due to puncture of refrigerant tubing; follow handling instructions carefully. 	<ul style="list-style-type: none"> • Servicing shall be done by trained service personnel with certified competence in handling flammable refrigerants to minimize the risk of possible ignition due to incorrect parts or improper service. • Component parts shall be replaced with like components so as to minimize the risk of possible ignition due to incorrect parts. • Dispose of properly in accordance with federal or local regulations. • Do not pierce or burn. • Be aware that refrigerants may not contain an odor. • Do not damage the refrigeration circuit. • See nameplate for R-290 refrigerant charge: <ul style="list-style-type: none"> • If greater than 114 g (4 oz.), do not install in public corridor or lobby. • If greater than 152 g (5.3 oz.), do not install within 6 m (20 ft) of open flame. • The appliance shall be stored in a room without continuously operating ignition sources (for example: open flames, an operating gas appliance, or an operating electric heater). 	

⚠ DANGER

- Do not place any potential ignition sources in or near the appliance.
- Keep clear of obstruction all ventilation openings in the appliance enclosure or in the structure for building-in.
- No potential sources of ignition are to be used in the searching for or detection of refrigerant leaks.
- Do not use electrical appliances inside the appliance unless they are of the type recommended by the manufacturer.
- Do not store explosive substances such as aerosol cans with a flammable propellant in this appliance.
- Check that cabling will not be subject to wear, corrosion, excessive pressure, vibration, sharp edges, or any other adverse environmental effects. The check shall also take into account the effects of aging or continual vibration from sources such as compressors or fans.
- Ensure that the area is in the open or that it is adequately ventilated before breaking into the system or conducting any hot work. A degree of ventilation shall continue during the period that the work is carried out. The ventilation should safely disperse any released refrigerant and preferably expel it externally into the atmosphere.

Risque D'Incendie ou D'Explosion Fluide Frigorigène Inflammable Utilisé

- Seuls des techniciens de service qualifiés doivent installer et entretenir l'appareil.
- Aucune installation, opération ou maintenance ne doit être entreprise avant que le technicien n'ait lu attentivement ce manuel d'instructions. Toutes les précautions de sécurité doivent être suivies.
- Aucune opération d'entretien ne doit être entreprise avant que le technicien n'ait lu attentivement le manuel d'entretien disponible sur le site www.perlick.com. Toutes les précautions de sécurité doivent être suivies.
- Cet appareil doit être installé conformément à la norme de sécurité pour les systèmes de réfrigération ANSI/ASHRAE 15.
- Suivez attentivement les instructions de manutention conformément aux règlements nationaux.
- Ne pas utiliser de dispositifs mécaniques ou d'autres moyens pour accélérer le processus de dégivrage ou pour nettoyer, autres que ceux recommandés par le fabricant.
- Ne pas perforer la conduite de fluide frigorigène. Risque d'incendie ou d'explosion en cas de perforation d'une canalisation de fluide frigorigène; suivez attentivement les instructions de manutention.
- L'entretien doit être effectué par du personnel formé et certifié pour la manipulation de réfrigérants inflammables afin de réduire au minimum le risque d'inflammation dû à des pièces incorrectes ou à un entretien inadéquat.

⚠ DANGER Continué

- Les pièces doivent être remplacées par des pièces similaires, de manière à réduire au minimum le risque d'inflammation dû à des pièces incorrectes.
 - Mettre au rebut conformément aux règlements fédéraux ou locaux.
 - Ne pas percer ou brûler.
 - Attention, les fluides frigorigènes peuvent ne pas dégager d'odeur.
 - Ne pas endommager les composants du circuit de réfrigération.
 - Voir plaque signalétique pour la charge de réfrigérant R-290:
 - Si elle est supérieure à 114 g (4 oz.), ne pas l'installer dans un couloir public ou un hall d'entrée.
 - Si elle est supérieure à 152 g (5,3 oz.), ne pas l'installer à moins de 6 m (20 pi) d'une flamme nue.
 - L'appareil doit être entreposé dans un local ne contenant pas de sources d'inflammation permanentes (flammes nues, appareil à gaz ou dispositif de chauffage électrique en fonctionnement, par exemple).
 - Ne placer aucune source d'inflammation potentielle à l'intérieur ou à proximité de l'appareil.
 - Ne pas obstruer les ouvertures de ventilation dans l'enceinte de l'appareil ou dans la structure d'encastrement.
 - Aucune source potentielle d'inflammation ne doit être utilisée pour rechercher ou détecter des fuites de réfrigérant.
 - Ne pas utiliser d'appareils électriques à l'intérieur de l'appareil, sauf s'ils sont du type recommandé par le fabricant.
 - Ne pas entreposer dans cet appareil des substances explosives telles que des bombes aérosols contenant un gaz propulseur inflammable.
- Vérifier que le câblage ne sera pas soumis à l'usure, à la corrosion, à une pression excessive, à des vibrations, à des arêtes vives ou à tout autre effet environnemental négatif. Le contrôle doit également prendre en compte les effets du vieillissement ou des vibrations continues provenant de sources telles que les compresseurs ou les ventilateurs.
 - S'assurer que la zone est à l'air libre ou qu'elle est correctement ventilée avant de pénétrer dans le système ou d'effectuer un travail à chaud. Une certaine ventilation doit être maintenue pendant la durée des travaux. La ventilation doit permettre de disperser en toute sécurité tout réfrigérant libéré et, de préférence, de l'expulser dans l'atmosphère.

WARNING

The appliance should be destined only to the use for which it has been expressly conceived. Any other use should be considered improper and therefore dangerous. The manufacturer cannot be held responsible for injury or damage resulting from improper, incorrect, and unreasonable use. Failure to install, operate, and maintain the appliance in accordance with this manual will adversely affect safety, performance, component life, and warranty coverage and may result in costly water damage. **To reduce the risk of death, electric shock, serious injury, or fire, follow basic precautions including the following:**

- This appliance is not intended for use above 2,000 m (6,561 ft). Installation above 2,000 m (6,561 ft) may adversely affect safety, performance, and component life.
- Wear appropriate personal protective equipment (PPE) when servicing the appliance.
- The appliance must be installed in accordance with applicable national, state, and local codes and regulations.
- The appliance requires an independent power supply of proper capacity. See the nameplate for electrical specifications. Failure to use an independent power supply of proper capacity can result in a tripped breaker, blown fuse, damage to existing wiring, or component failure. This could lead to heat generation or fire.
- **THE APPLIANCE MUST BE GROUNDED.** The appliance is equipped with a NEMA 5-15 three-prong grounding plug  to reduce the risk of potential shock hazards. It must be plugged into a properly grounded, independent 3-prong wall outlet. If the outlet is a 2-prong outlet, it is your personal responsibility to have a qualified electrician replace it with a properly grounded, independent 3-prong wall outlet. Do not remove the ground prong from the power cord and do not use an adapter plug. Failure to follow these instructions may result in death, electric shock, or fire.
- To reduce the risk of electric shock, do not touch the control switch or plug with damp hands.
- To reduce the risk of electric shock, make sure the control switch is in the "OFF" position before plugging in or unplugging the appliance.
- Unplug the appliance before servicing.
- Do not use an appliance with a damaged power cord. The power cord should not be altered, jerked, bundled, weighed down, pinched, or tangled. Such actions could result in electric shock or fire. To unplug the appliance, be sure to pull the plug, not the cord, and do not jerk the cord.
- Do not use an extension cord.
- If the supply cord is damaged, it must be replaced by the manufacturer, its service agent, or similarly qualified persons in order to avoid a hazard. Upon replacement, the GREEN ground wire in the power cord must be connected to the designated grounding screw.
- Do not make any alterations to the appliance. Alterations could result in electric shock, injury, fire, or damage to the appliance.
- Appliance is heavy. Use care when lifting or positioning. Work in pairs when needed to prevent injury or damage.

⚠ WARNING continued

- The appliance is not intended for use by persons (including children) with reduced physical, sensory, or mental capabilities, or lack of experience and knowledge, unless they have been given supervision or instruction concerning use of the appliance by a person responsible for their safety.
- Do not splash, pour, or spray water directly onto or into the appliance. This might cause short circuit, electric shock, corrosion, or failure.
- Children should be properly supervised around the appliance.
- Do not climb, stand, or hang on the appliance or allow children or animals to do so. Serious injury could occur or the appliance could be damaged.
- Be careful not to pinch fingers when opening and closing the door. Be careful when opening and closing the door when children are in the area.
- Do not use combustible spray or place volatile or flammable substances in or near the appliance. They might catch fire.
- Keep the area around the appliance clean. Dirt, dust, or insects in the appliance could cause harm to individuals or damage to the appliance.

NOTICE

- Follow the water supply, drain connection, and maintenance instructions carefully to reduce the risk of costly water damage.
- In areas where water damage is a concern, install in a contained area with a floor drain.
- Install the icemaker in a location that stays above freezing. Normal operating ambient temperature must be within 45°F to 100°F (7°C to 38°C).

NOTICE

- Test the drain pump operation every time the appliance is cleaned and sanitized. See "IV.D. Drain Pump" for details. If the drain pump is not operating properly, water could back up and overflow, leading to costly water damage.
- To help ensure that the ice storage bin drain remains clear, follow the instructions in "IV.C. Ice Storage Bin Drain" once every 3 months or as often as necessary for conditions. If the ice storage bin drain becomes clogged, water could build up in the bin and overflow, leading to costly water damage.
- Do not leave the appliance on during extended periods of non-use, extended absences, or in sub-freezing temperatures. To properly prepare the appliance for these occasions, follow the instructions in "V. Preparing the Appliance for Periods of Non-Use."
- If water collects in the ice storage bin and will not drain, turn off the appliance and close the water supply line shut-off valve. Call for service.
- If water seeps from the base of the appliance, turn off the appliance and close the water supply line shut-off valve. Call for service. Failure to do so could lead to costly water damage.
- Do not place objects on top of the appliance.
- The ice storage bin is for ice use only. Do not store anything else in the ice storage bin.
- Keep ventilation openings, in the appliance enclosure or in the built-in structure, clear of obstruction.
- Protect the floor when moving the appliance to prevent damage to the floor.
- Do not allow the appliance to bear any outside weight.

I. Specifications

A. Construction

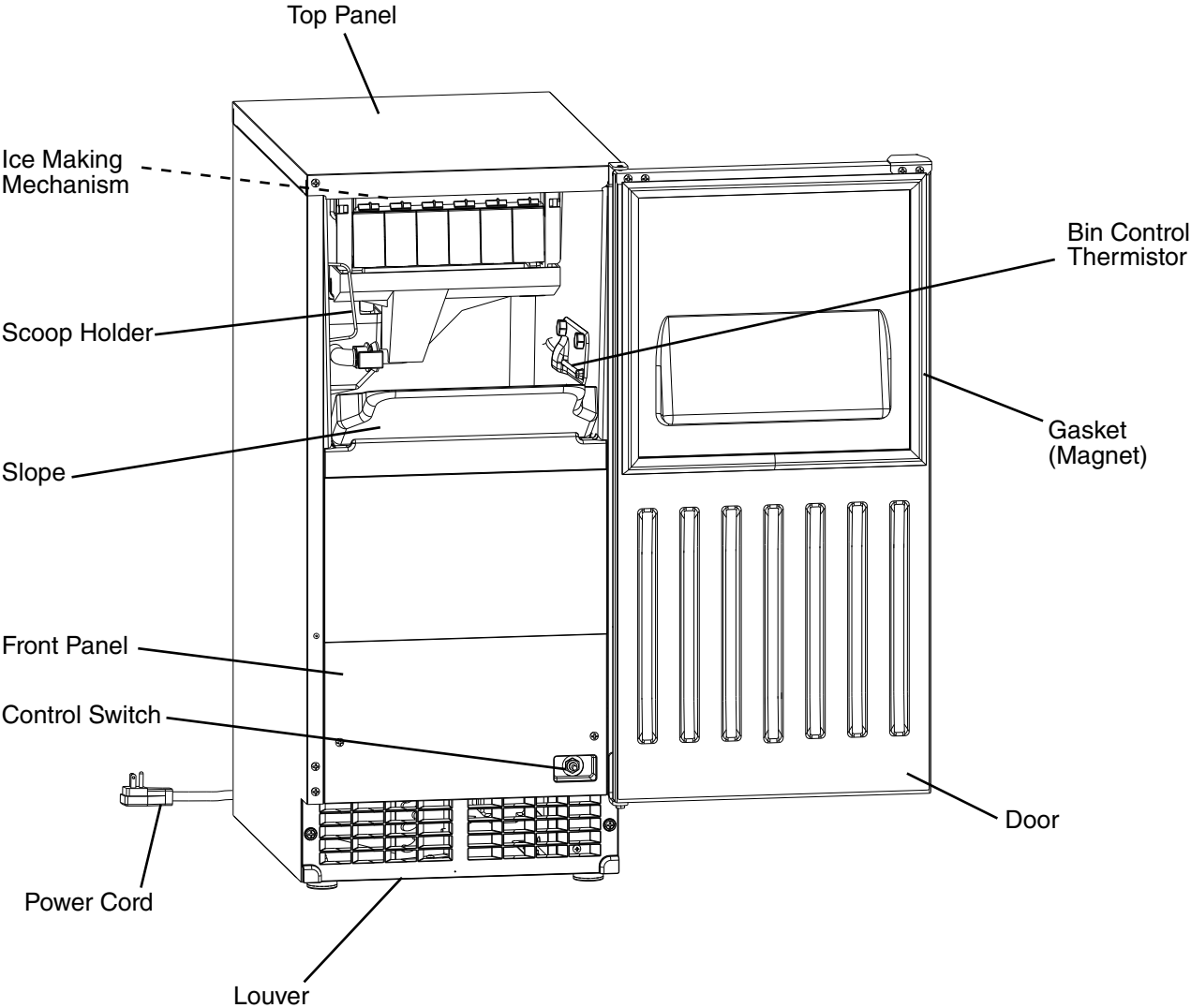

B. Electrical and Refrigerant Data

The nameplate provides electrical and refrigerant data. The nameplate is located inside the ice storage bin. For certification marks, see the nameplate.

We reserve the right to make changes in specifications and design without prior notice.

Model Number	HP15CI-L(-R)(-W)	HA15CI-L(-R)(-W)
AC SUPPLY VOLTAGE	~115/60/1	~115/60/1
AMPERES	2.2	2.2
DESIGN PRESSURE kPa (PSI)	HI-2069 (300) LO-896 (130)	HI-2069 (300) LO-896 (130)
REFRIGERANT g (OZ.)	R-290 65 (2.3)	R-290 57 (2.0)
CLIMATE CLASS	5	5
INSULATION BLOWING GAS	HFO 1233zd(E)	HFO 1233zd(E)
MINIMUM ROOM FLOOR AREA M ² (FT ²)	3.1 (33.5)	2.7 (29.4)
HARVEST RATE	≤1,000 LB/DAY (BATCH)	≤1,000 LB/DAY (BATCH)
IP RATING	IPX4	IPX4

Note: Climatic Class 5: This appliance electrical safety tested for operation in maximum ambient temperature of 104°F (40°C) with 40% relative humidity. However, normal operating ambient temperature must be within 45°F to 100°F (7°C to 38°C); Normal operating water temperature must be within 45°F to 90°F (7°C to 32°C). Operation of the appliance, for extended periods, outside of these normal temperature ranges may affect appliance performance.

C. Dimensions/Connections

1. HP15CI-L(-R)

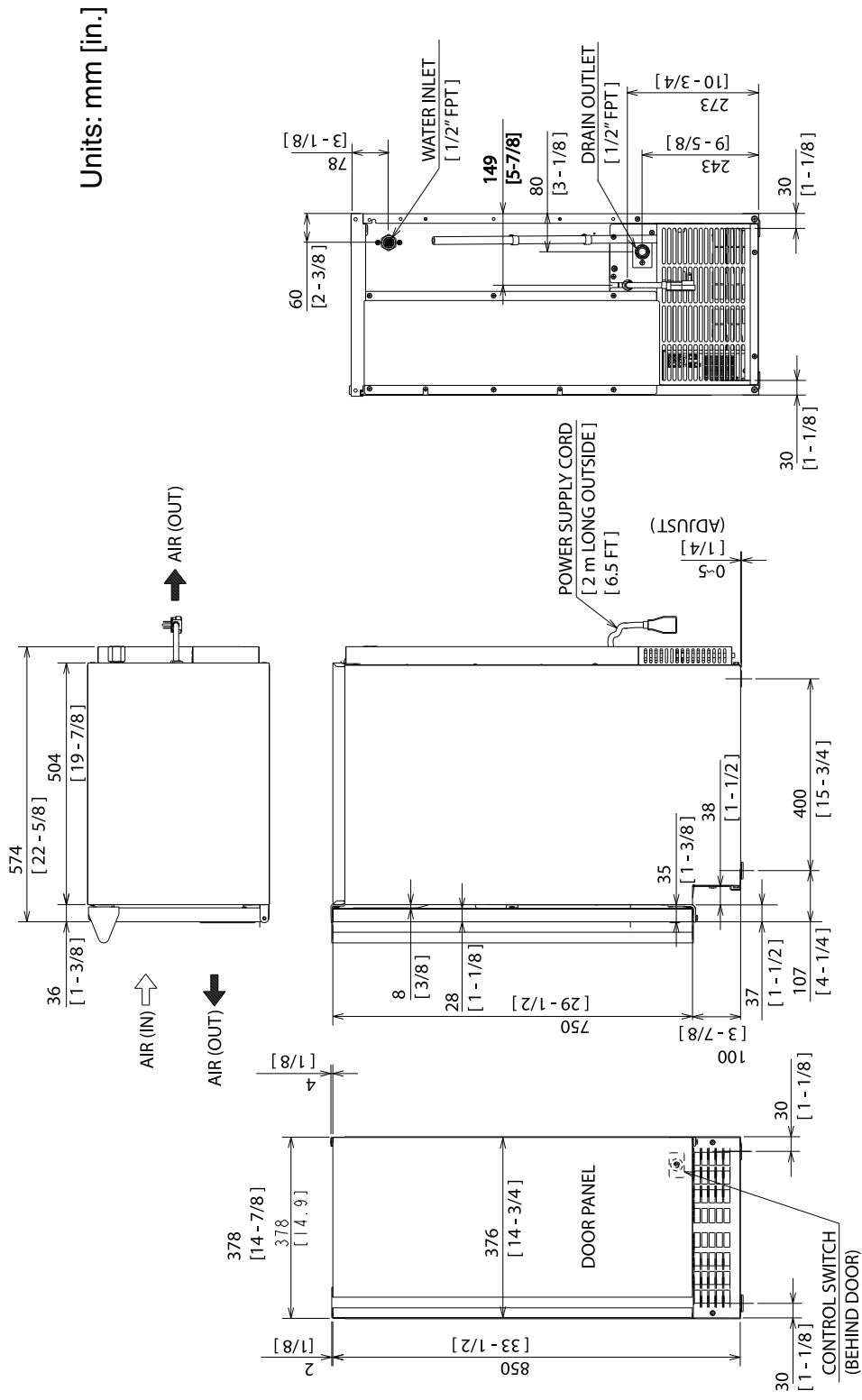

3. HA15CI-L(-R)

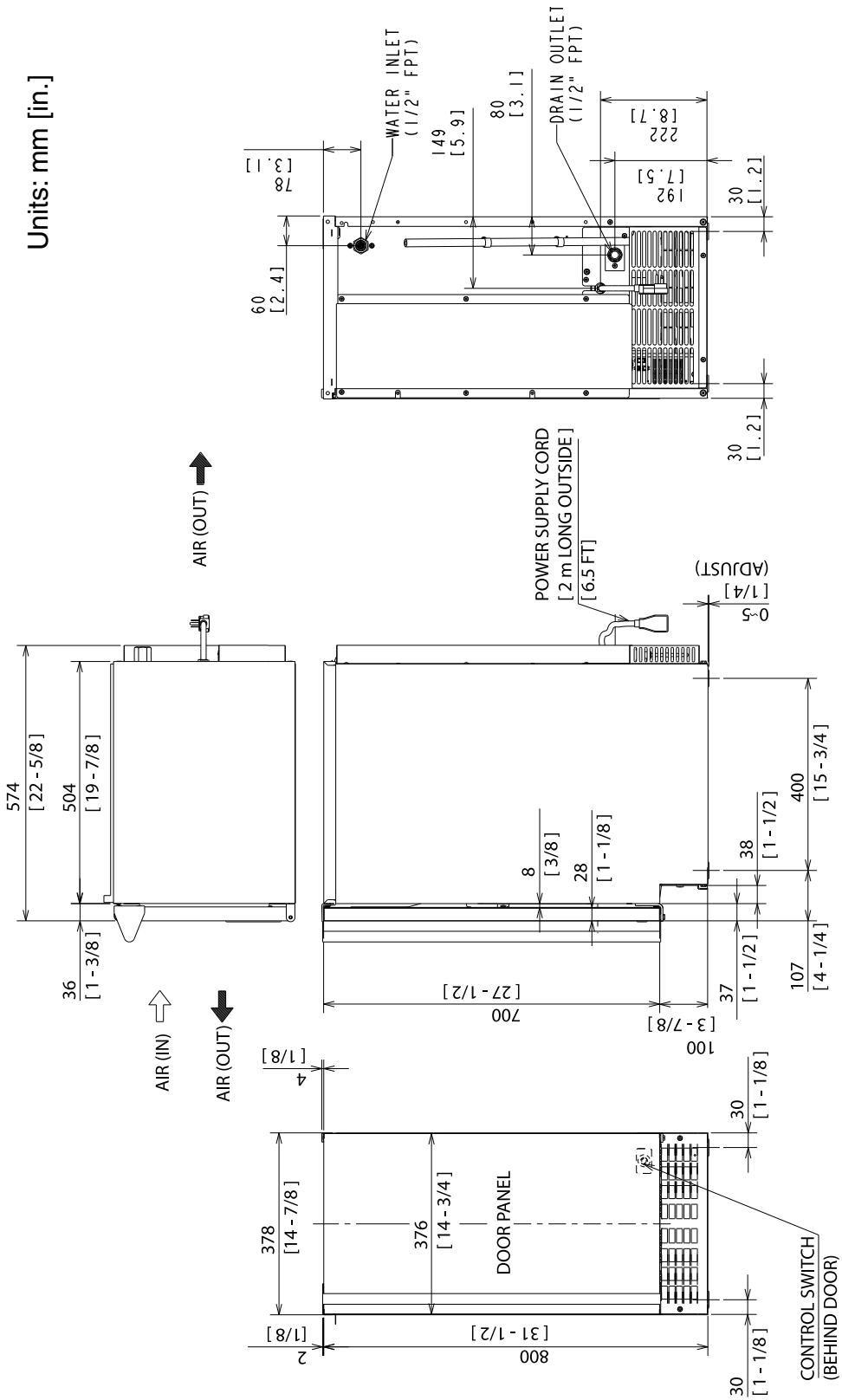

II. Installation Instructions

WARNING

- This appliance must be installed in accordance with applicable national, state, and local codes and regulations.
- This appliance to be installed in accordance with the Safety Standard for Refrigeration Systems ANSI/ASHRAE 15.
- Failure to install, operate, and maintain the appliance in accordance with this manual will adversely affect safety, performance, component life, and warranty coverage and may result in costly water damage.
- **CHOKING HAZARD:** Ensure all components, fasteners, and thumbscrews are securely in place after installation. Make sure that none have fallen into the ice storage bin.

A. Location

1. General

This appliance is approved for indoor or outdoor use.

This appliance uses an A3 flammable refrigerant. For refrigerant charge and room floor area requirement, see the table below.

DANGER



R-290 Class A3 Flammable Refrigerant Used

Model	R-290 Refrigerant Charge g (oz.)	Minimum Room Floor Area (operating or storage) Superficie Minimale du Local (service ou stockage) m ² (ft ²); m ² (pi ²)
HP15CI-L(-R)(-W)	65 (2.3)	3.1 (33.5)
HA15CI-L(-R)(-W)	57 (2.0)	2.7 (29.4)



≥ Area m² (ft²) (see "Minimum Room Floor Area" above)
≥ Superficie m² (pi²) (voir « Superficie Minimale du Local » ci-dessus)

!

R-290 Refrigerant Charge:

- If greater than 114 g (4 oz.), do not install in public corridor or lobby.
- If greater than 152 g (5.3 oz.), do not install within 6 m (20 ft) of open flame.

Charge de réfrigérant R-290:

- Si elle est supérieure à 114 g (4 oz.), ne pas l'installer dans un couloir public ou un hall d'entrée.
- Si elle est supérieure à 152 g (5,3 oz.), ne pas l'installer à moins de 6 m (20 pi) d'une flamme nue.

This appliance is not intended for use above 2,000 m (6,561 ft). Installation above 2,000 m (6,561 ft) may adversely affect safety, performance, and component life.

NOTICE

- Normal operating ambient temperature must be within 45°F to 100°F (7°C to 38°C); Normal operating water temperature must be within 45°F to 90°F (7°C to 35°C). Operation of the appliance, for extended periods, outside of these normal temperature ranges may affect appliance performance.
- This appliance will not work at sub-freezing temperatures. To prevent damage to the water supply line, drain the appliance if the air temperature is going to go below 32°F (0°C). See "V. Preparing the Appliance for Periods of Non-Use."

- The appliance should not be located next to ovens, grills, or other high heat producing equipment.
- The location must provide a firm foundation for the appliance.
- This appliance requires no side or top clearance. But allow enough space at rear for water supply and drain connections and at least 15" (38 cm) clearance at front.
- The appliance must be at floor level on a finished floor even if under a cabinet. In areas where water damage is a concern, install in a contained area with a floor drain.

2. Built-In Installation Site

NOTICE

- Do not let the weight of the counter rest on the icemaker.
- Do not install the icemaker in a corner where the door will interfere with other equipment or where the icemaker cannot be pulled out for service.

Installation Space

Model	Height	Width	Depth
HP15CI-L(-R)(-W)	34" (864 mm) minimum	15" (381 mm) minimum	24" (610 mm) minimum
HA15CI-L(-R)(-W)	32" (814 mm) minimum		

Between Two Cabinets

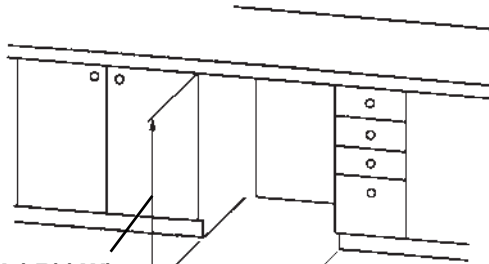

HP15CI-L(-R)(-W)
Min. 34"
(864 mm)
HA15CI-L(-R)(-W)
Min. 32"
(814 mm)

Min. 15"
(381 mm)

Between a Cabinet and the End of a Counter

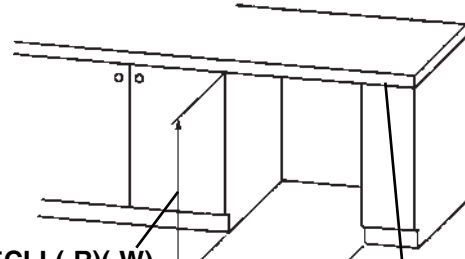

HP15CI-L(-R)(-W)
Min. 34"
(864 mm)
HA15CI-L(-R)(-W)
Min. 32"
(814 mm)

Min. 15"
(381 mm)

Support: Do not let the weight of the counter rest on the appliance

Between a Cabinet and a Wall or Tall Cabinet

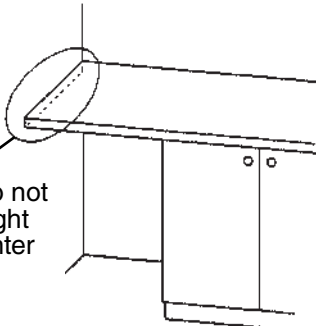

Secure: Do not let the weight of the counter rest on the appliance

In a Corner

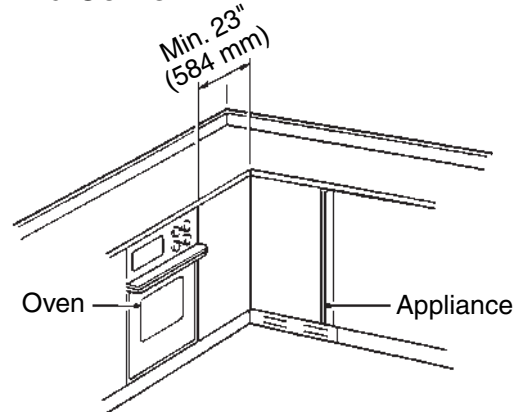

Min. 23"
(584 mm)

Oven

Appliance

B. Checks Before Installation

- Visually inspect the exterior of the shipping container and immediately report any damage to the carrier. Upon opening the container, any concealed damage should also be immediately reported to the carrier.
- Remove the shipping carton, tape, and packing material. If any are left in the appliance, it will not work properly.
- Remove the package containing the accessories.
- Remove the protective plastic film from the panels. If the appliance is exposed to the sun or to heat, remove the film after the appliance cools.
- See the rating label on the rear panel or the nameplate inside the ice storage bin area, and check that your voltage supplied corresponds with the voltage specified on the rating label/nameplate.

C. HP15CI-W, HA15CI-W Door

1. HP15CI-W, HA15CI-W

a) Overlay Panel Fabrication and Attachment

IMPORTANT

The overlay panel must be crafted by a professional cabinet maker to ensure quality results.

(1) Parts

Ensure that all parts required for the overlay panel assembly are contained in the accessories bag.

Overlay Panel Parts			
No.	Description	Part Number	Qty.
1	Threaded Wood Insert	4A4004-01	6
2	T2 Screw 4x8 SS	7P32-0408	3
3	Pan Head Screw M4x25 SS	7C12-0425	4
4	Truss Head Screw M4x8 SS	7C32-0408	2
5	Canoe Clip	4A5835-01	2
6	Sheet Metal Bracket	4A3998-01	1

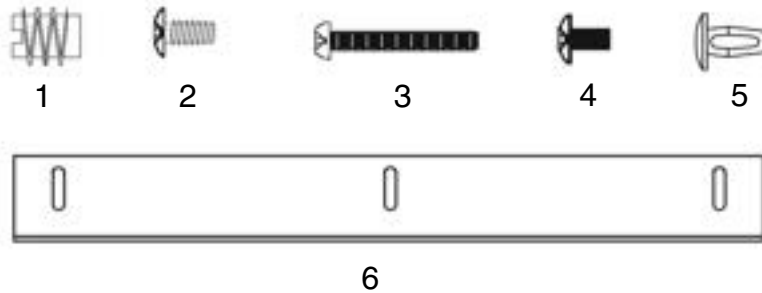

(2) Overlay Panel Specification

Use the specification that applies to your appliance (HP15CI-W or HA15CI-W) and the directions that follow to prepare your overlay panel.

(a) HP15CI-W

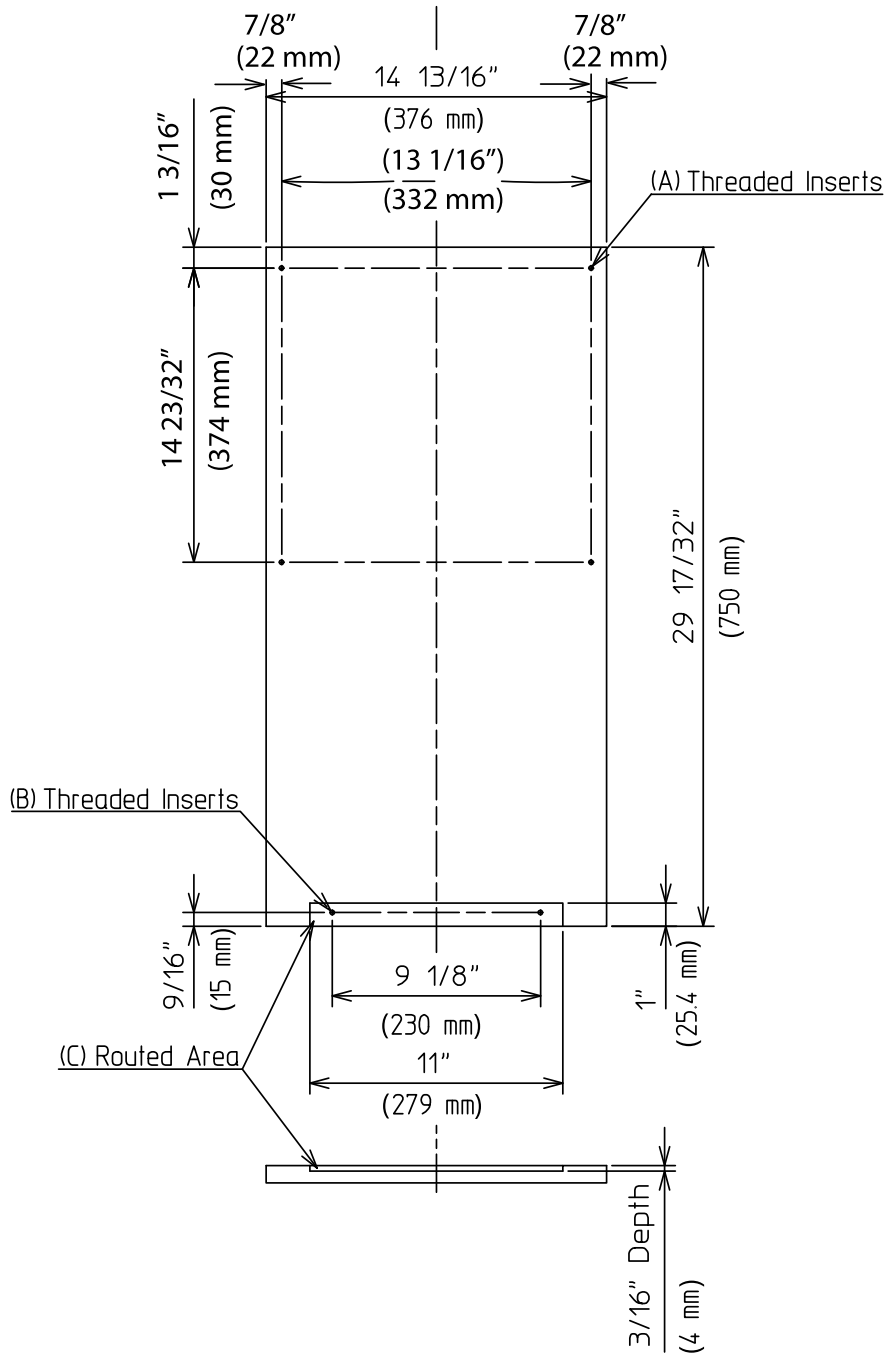

HP15CI-W Overlay Panel Specification	
Overlay Panel Height	29 17/32" (750 mm)
Overlay Panel Width	14 13/16" (376 mm)
Overlay Panel Thickness	5/8" (16 mm) minimum; 3/4" (19 mm) maximum
Overlay Panel and Door Weight (total)	20 lb. (9 kg) maximum

(b) HA15CI-W

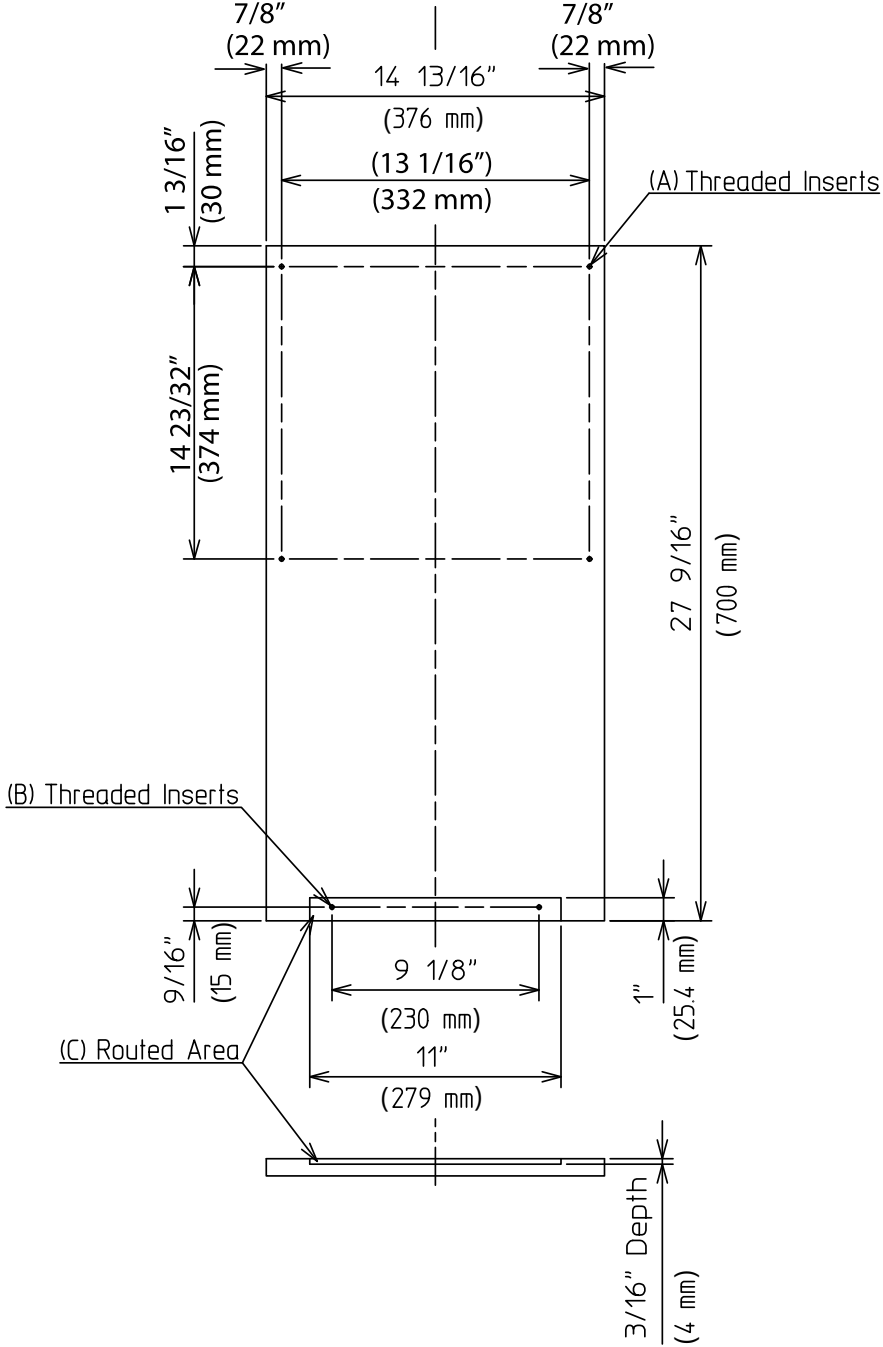

HA15CI-W Overlay Panel Specification	
Overlay Panel Height	27 9/16" (700 mm)
Overlay Panel Width	14 13/16" (376 mm)
Overlay Panel Thickness	5/8" (16 mm) minimum; 3/4" (19 mm) maximum
Overlay Panel and Door Weight (total)	20 lb. (9 kg) maximum

(3) Fabrication of Overlay Panel

Fabricate the overlay panel as outlined in the applicable specification on the previous pages and the instructions below.

- 1) Route a channel at the bottom of the overlay panel to the proper dimensions. See "(C) Routed Area" in the specification diagram and Fig. 1.
- 2) Drill six 1/4" diameter (hardwood may require slightly larger diameter) holes 3/8" (10 mm) deep in the locations designated. **NOTICE! Use care when drilling holes for mounting hardware. All drilled holes must be straight and drilled to the correct diameter and depth.** See "(A) Threaded Inserts" and "(B) Threaded Inserts" in the specification diagram and Fig. 2.

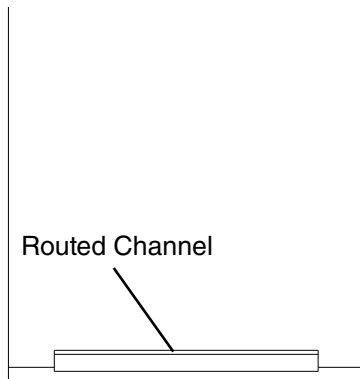

Fig. 1

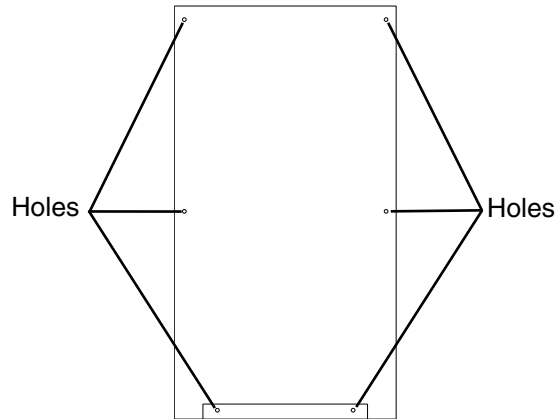

Fig. 2

- 3) Screw the 6 threaded wood inserts into the 1/4" holes drilled in the previous step. Make sure that the inserts are threaded straight and that the tops of the inserts are flush to the overlay panel surface. Otherwise, the overlay panel cannot be properly fastened to the door.
- 4) Mount the door handle hardware. It is recommended to mount the door handle hardware on the edge opposite of the door hinge side (optional hinge reversal is covered in step 6). Countersunk screw heads are required to ensure that the hardware fasteners do not interfere with the overlay panel fitting flush with the door.
- 5) While maintaining a hold on the door, remove the hinge stop pin from hinge (B). Pull out the bottom of the door slightly and gently remove the door from hinge (A). See Fig. 3. If you are leaving the door right-hinged, skip to step 7. If you would like to reverse the door swing, proceed to step 6.

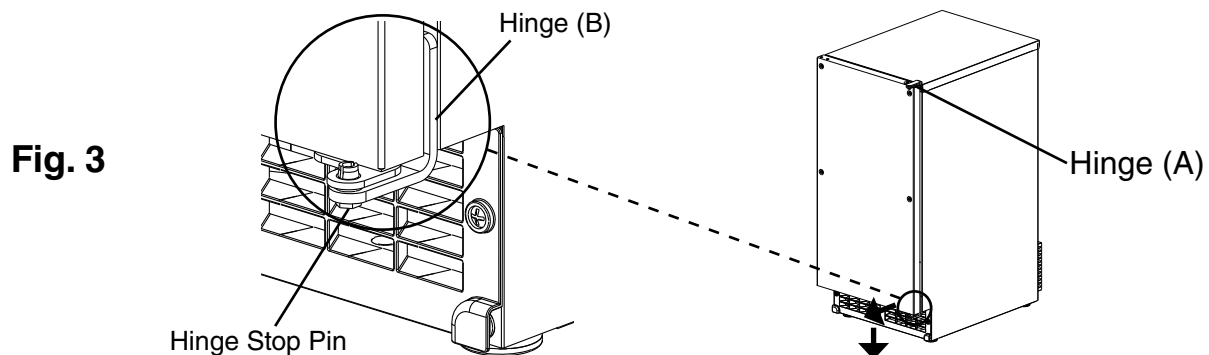

Fig. 3

6) If you would like to reverse the door swing, do the following:

- a) Contact your local distributor to purchase Kit HS-0229. The kit contains "hinge (A)-left."
- b) Remove the 2 screws securing the top panel, then lift it off. See Fig. 4.
- c) Remove hinge (A)-right and the bracket from the right side of the appliance. Set aside hinge (A)-right; it is not needed. Remove the top brace from the left side. Fasten hinge (A)-left and the bracket to the left side and the top brace to the right side. See Fig. 5.

Note: When on the proper side, the gasket notch for hinge (A) is to the inside.

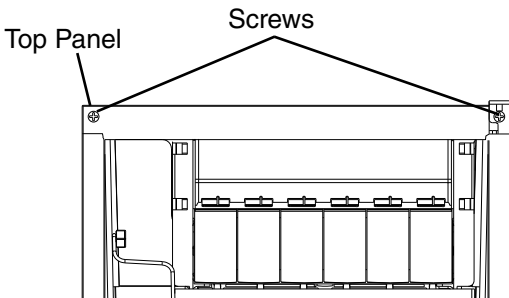

Fig. 4

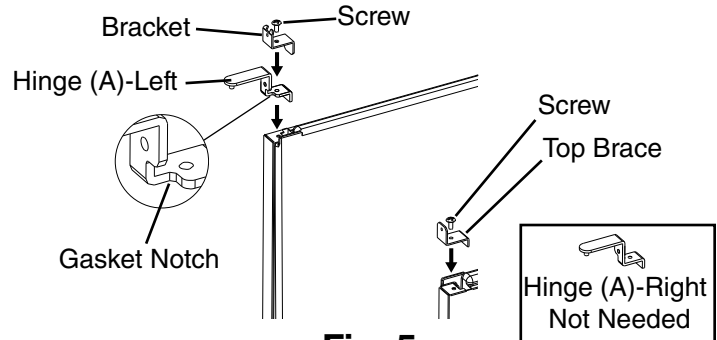

Fig. 5

- d) Remove hinge (B) from the right side of the appliance and the 2 filler screws from the left side. Attach the 2 filler screws to the right side and attach hinge (B) to the left side. See Fig. 6.

- e) Rotate the top panel 180° from its previous position. This brings the notch that was previously in the right rear to the left front. See Fig. 7. Hook the rear part of the panel on the body, then secure the front with the 2 screws removed in step 6b.

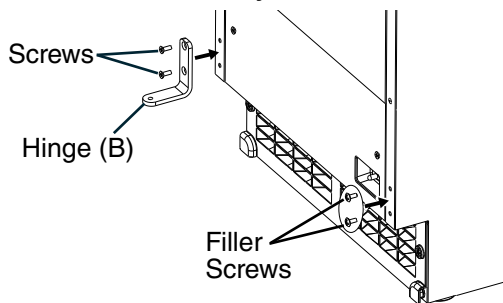

Fig. 6

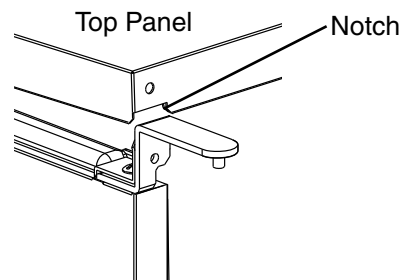

Fig. 7

- f) Remove hinge (C1) from the top right part of the door, flip it and reattach to the bottom left. Remove hinge (C2) from the bottom right part of the door, flip it and reattach to the top left. See Fig. 8. Proceed to step 7.

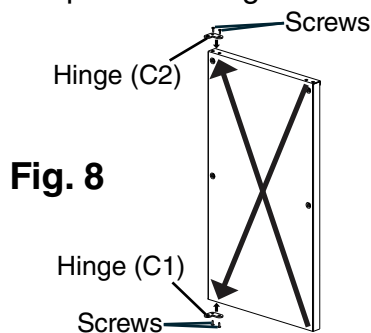

Fig. 8

- 7) Remove the bushings from hinge (C1) and hinge (C2) (the hinges attached to the door). See Fig. 9.
- 8) Remove the gasket from the door. See Fig. 10.

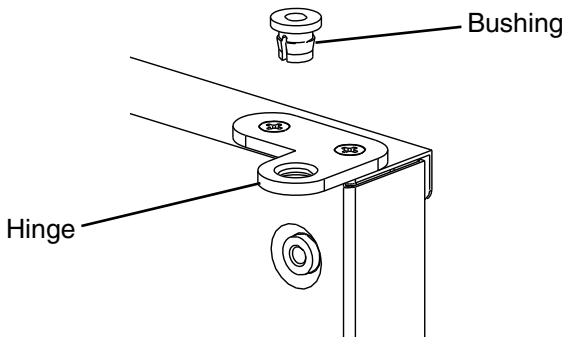

Fig. 9

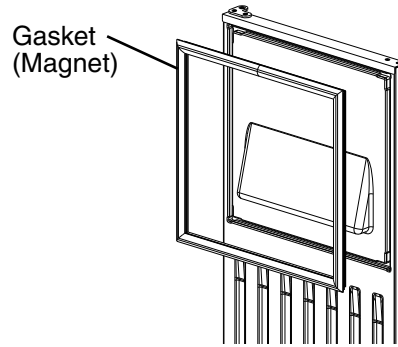

Fig. 10

- 9) Temporarily fasten the overlay panel to the door using 2 of the M4x25 pan head screws provided. **NOTICE! Ensure that the back surface of overlay panel is flat before attaching.** See Fig. 11.
- 10) Mark the centerpoint of the hinge (C1) and hinge (C2) holes that extend over the overlay panel. See Fig. 12.

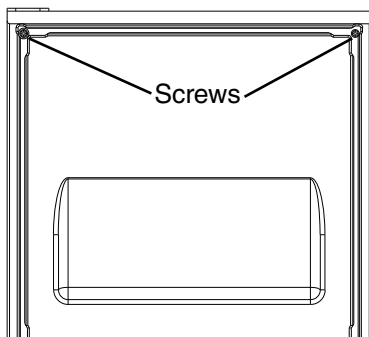

Fig. 11

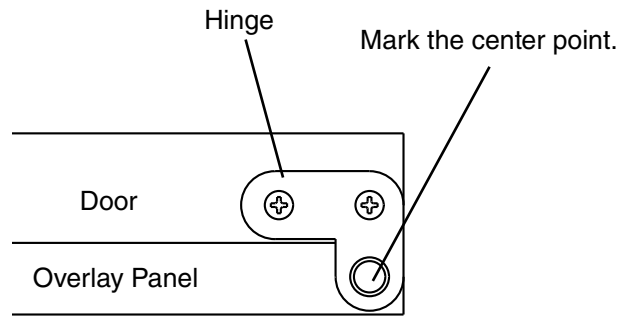

Fig. 12

- 11) Remove the overlay panel from the door.
- 12) Drill 3/8" diameter holes 1/4" (7 mm) deep where you marked on the overlay panel to accommodate the hinge (C1) and hinge (C2) bushings.

(4) Attachment of Overlay Panel to Door

- 1) Fasten the sheet metal bracket to the overlay panel using the two M4x8 truss head screws provided. **Snug the screws, but do not tighten.** See Fig. 13.
- 2) Temporarily fasten the overlay panel to the door using 2 of the M4x25 pan head screws provided. See Fig. 14.

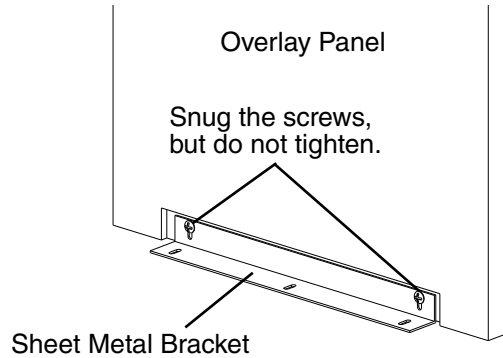

Fig. 13

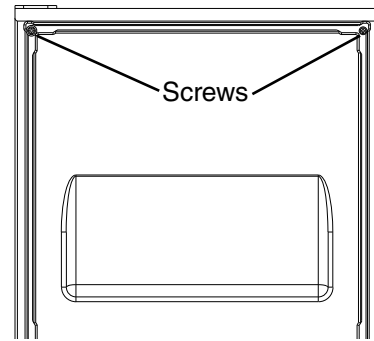

Fig. 14

- 3) Adjust the sheet metal bracket so that it is flush with the bottom of the door. See Fig. 15.
- 4) Remove the overlay panel from the door and tighten the two M4x8 truss head screws securing the sheet metal bracket to the overlay panel. See Fig. 16.

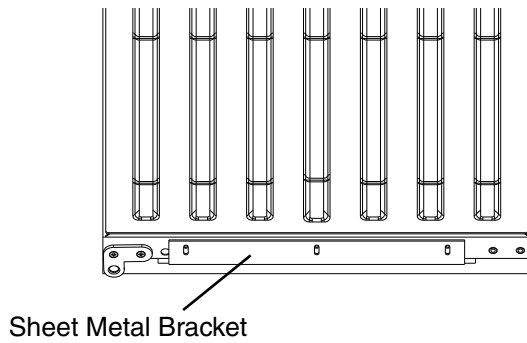

Fig. 15

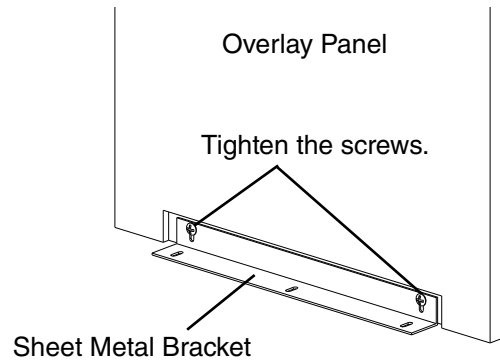

Fig. 16

- 5) Fasten the overlay panel to the door using the four M4x25 pan head screws provided. **Snug the screws, but do not tighten.** See Fig. 17.
- 6) Fasten the sheet metal bracket to the bottom of the door with the three T2 screws provided. Tighten the screws to the door. See Fig. 18.

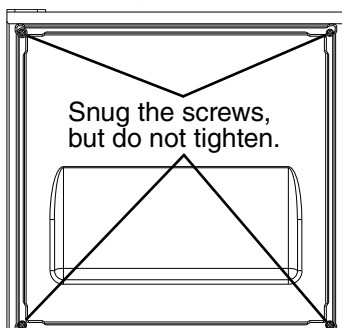

Fig. 17

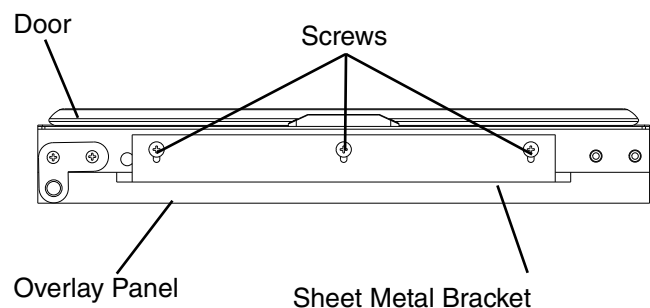

Fig. 18

- 7) Tighten the four M4x25 pan head screws installed in step 5. See Fig. 19.
- 8) Replace the door gasket in its proper orientation. Reinsert the bushings into hinge (C1) and hinge (C2) (the hinges attached to the door). See Fig. 20.

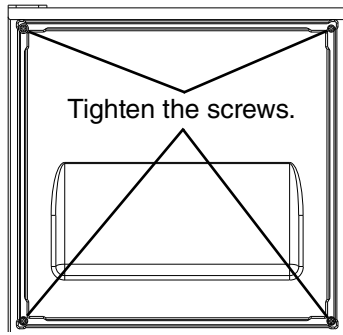

Fig. 19

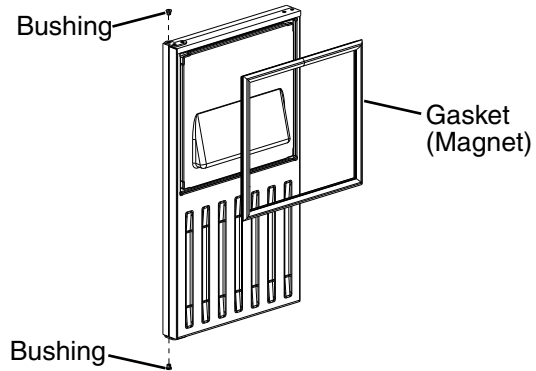

Fig. 20

- 9) Attach the door to hinge (A), then continue to maintain a hold on the door. Screw the hinge stop pin into hinge (B) until it is tight. See Fig. 21.
- 10) Insert the 2 canoe clips included in the accessory bag into the holes on top of the door. See Fig. 22.

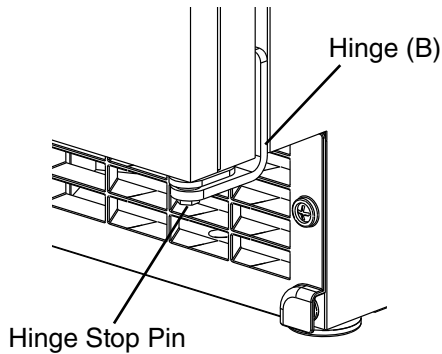

Fig. 21

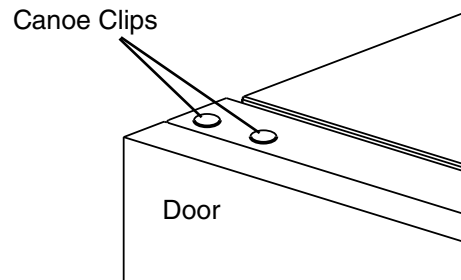

Fig. 22

- 11) Insert the 4 canoe clips included in the accessory bag into the upper and lower holes on the inside of the door opposite from the door handle. See Fig. 23. These holes are provided to allow for door reversal and must be filled when not used.

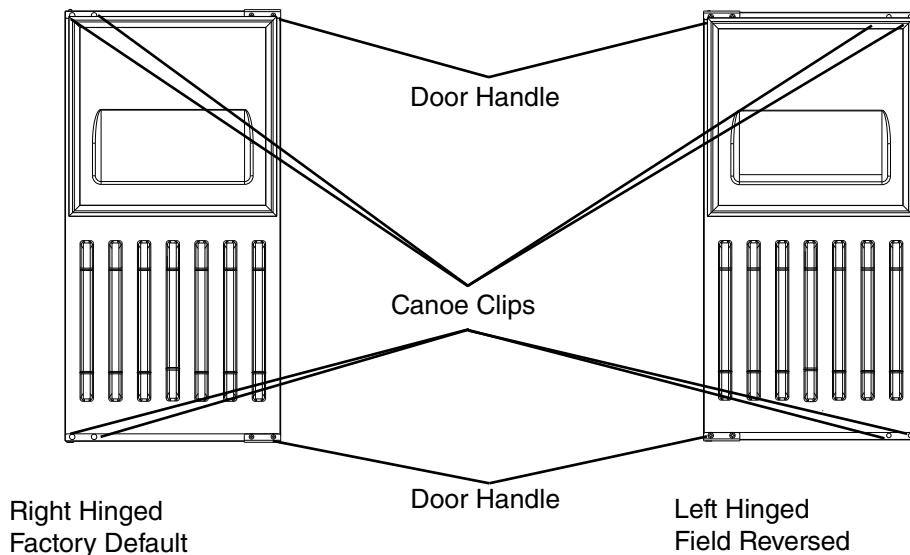



Fig. 23

D. Setup

- 1) Position the appliance in the selected permanent location.
- 2) Level the appliance from side-to-side and front-to-rear by adjusting the feet.

E. Electrical Connection

WARNING

- Electrical connection must meet national, state, and local electrical code requirements. Failure to meet these code requirements could result in death, electric shock, serious injury, fire, or severe damage to equipment.
 - This appliance requires an independent power supply of proper capacity. See the nameplate for electrical specifications. Failure to use an independent power supply of proper capacity can result in a tripped breaker, blown fuse, damage to existing wiring, or component failure. This could lead to heat generation or fire.
 - **THE APPLIANCE MUST BE GROUNDED:** This appliance is equipped with a NEMA 5-15 three-prong grounding plug  to reduce the risk of potential shock hazards. It must be plugged into a properly grounded, independent 3-prong wall outlet. If the outlet is a 2-prong outlet, it is your personal responsibility to have a qualified electrician replace it with a properly grounded, independent 3-prong wall outlet. Do not remove the ground prong from the power cord and do not use an adapter plug. Failure to follow these instructions may result in death, electric shock, or fire.
 - Do not use an extension cord.
 - To reduce the risk of electric shock, make sure the control switch is in the "OFF" position before plugging in or unplugging the appliance.
 - To reduce the risk of electric shock, do not touch the control switch or plug with damp hands.
 - Do not use an appliance with a damaged power cord. The power cord should not be altered, jerked, bundled, weighed down, pinched, or tangled. Such actions could result in electric shock or fire. To unplug the appliance, be sure to pull the plug, not the cord, and do not jerk the cord.
 - If the supply cord is damaged, it must be replaced by the manufacturer, its service agent, or similarly qualified persons in order to avoid a hazard. Upon replacement, the GREEN ground wire in the power cord must be connected to the designated grounding screw.
- Usually an electrical permit and services of a licensed electrician are required.
 - The maximum allowable voltage variation is ± 10 percent of the nameplate rating.

F. Water Supply and Drain Connections

⚠ WARNING

- Water supply and drain connections must be installed in accordance with applicable national, state, and local regulations.
- Connect to potable water supply only. Do not connect to a hot-water supply.

NOTICE

- Normal operating water temperature must be within 45°F to 90°F (7°C to 32°C). Operation of the appliance, for extended periods, outside of this normal temperature range may affect appliance performance.
- Water supply pressure must be a minimum of 10 PSIG (68.9 kPa) and a maximum of 113 PSIG (779.1 kPa). If the pressure exceeds 113 PSIG (779.1 kPa), the use of a pressure reducing valve is required.
- To prevent damage to the appliance, do not operate the appliance when the water supply is off, or if the pressure is below 10 PSIG (68.9 kPa). Do not run the appliance until the proper water pressure is reached.
- External filters, strainers, or softeners may be required depending on water quality. Contact your local Perlick Certified Service Representative or local Perlick distributor for recommendations.
- Connect to potable water supply only. Do not connect to a hot-water supply.
- In areas where water damage is a concern, install in a contained area with a floor drain.
- Water line installation to the appliance is not warranted by Perlick.
- Water-hammer issues must be resolved by a qualified plumber before installing the appliance. Water hammer can cause appliance damage that may lead to water leakage or flooding.
- A minimum of 1/2" nominal ID hard pipe or equivalent is required for the drain line. Installing a smaller diameter drain line will reduce water flow and may lead to water leakage or flooding.
- Drain outlet is 1/2" FPT. A 1/2" nominal ID hard pipe or equivalent is required for the drain line. Installing a smaller diameter drain line will reduce water flow and may lead to water leakage or flooding. Installing a larger diameter drain line will reduce water pressure and may lead to water backup in the drain pump activating the overflow safety switch.
- Test the drain pump, operation every time the icemaker is cleaned and sanitized. See "III.D. Cleaning and Sanitizing" for details. If the drain pump is not operating properly, water could back up and overflow, leading to costly water damage.

Water Supply Inlet	Minimum Water Supply Line Size	Drain Outlet	Minimum Drain Line Size
1/2" Female Pipe Thread (FPT)	1/4" Nominal ID Copper Water Tubing or Equivalent	1/2" Female Pipe Thread (FPT)	1/2" Nominal ID Hard Pipe or Equivalent

- A plumbing permit and services of a licensed plumber may be required in some areas.
- A minimum of 1/4" nominal ID copper water tubing or equivalent is required for the water supply line.

- A water supply line shut-off valve and drain valve must be installed.
- Be sure there is sufficient extra water supply line and drain line for the appliance to be pulled out for service.
- Water supply pressure must be a minimum of 10 PSIG (68.9 kPa) and a maximum of 113 PSIG (779.1 kPa). If the pressure exceeds 113 PSIG (779.1 kPa), the use of a pressure reducing valve is required.
- Drain line should not be piped directly to the sewer system. An air gap of a minimum of 2 vertical inches (5 cm) must be between the end of the drain pipe from the appliance and the floor drain.
- Drain outlet is 1/2" FPT. A minimum of 1/2" nominal ID hard pipe or equivalent is required for the drain line. Installing a smaller diameter drain line will reduce water flow and may lead to water leakage or flooding. Be sure there is sufficient extra drain line for the appliance to be pulled out for service.
- For gravity drain installation, drain must have 1/4" fall per foot (2 cm per 1 m) on horizontal runs to get good flow. A vented tee connection is also required for proper flow. Extend the vent at least 12" (30 cm) above the drain outlet.

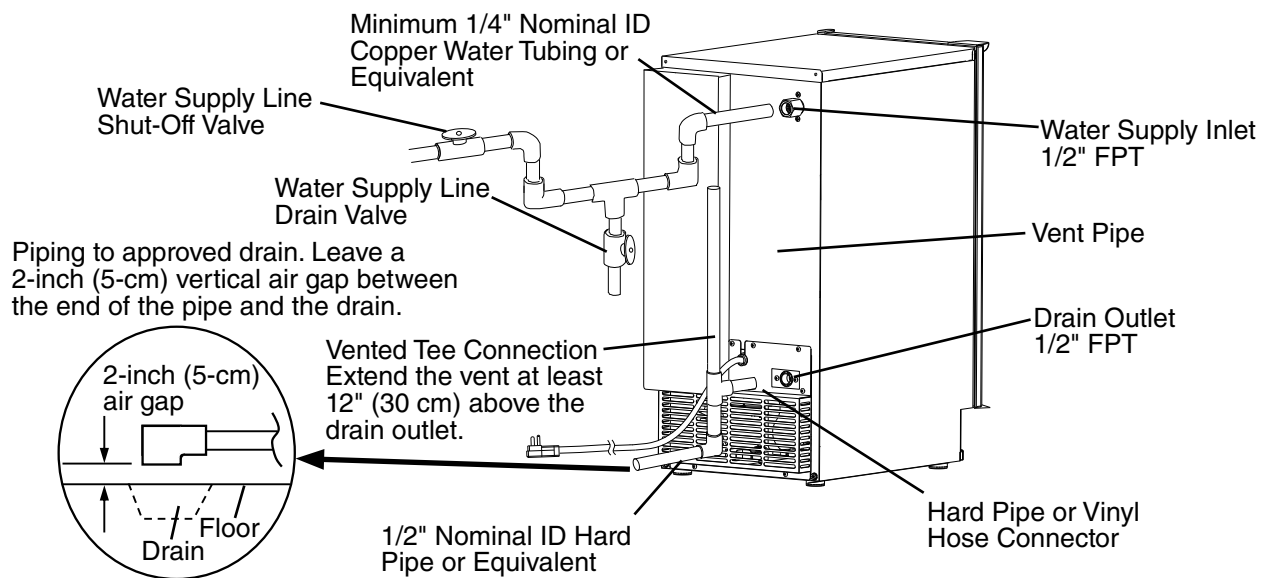

Fig. 24

a) Hard Pipe Drain Line Installation: When connecting with hard pipe, the maximum hard pipe length is 20 feet (6 m). The maximum discharge hard pipe lift height is 10 feet (3.05 m). See Fig. 25.

b) Vinyl Hose Drain Line Installation: When connecting with vinyl tubing, install the vinyl hose barbed fitting from the accessory bag into the drain outlet. Secure the discharge hose to the drain pump with the medium clamp provided in the accessory bag. **NOTICE! Do not over-tighten the clamp.** When routing the vinyl hose, do not allow traps or kinks in the hose that will restrict water flow. The maximum discharge hose length is 20 feet (6 m). The maximum discharge hose lift height is 10 feet (3.05 m). Cut excess hose as needed. See Fig. 25.

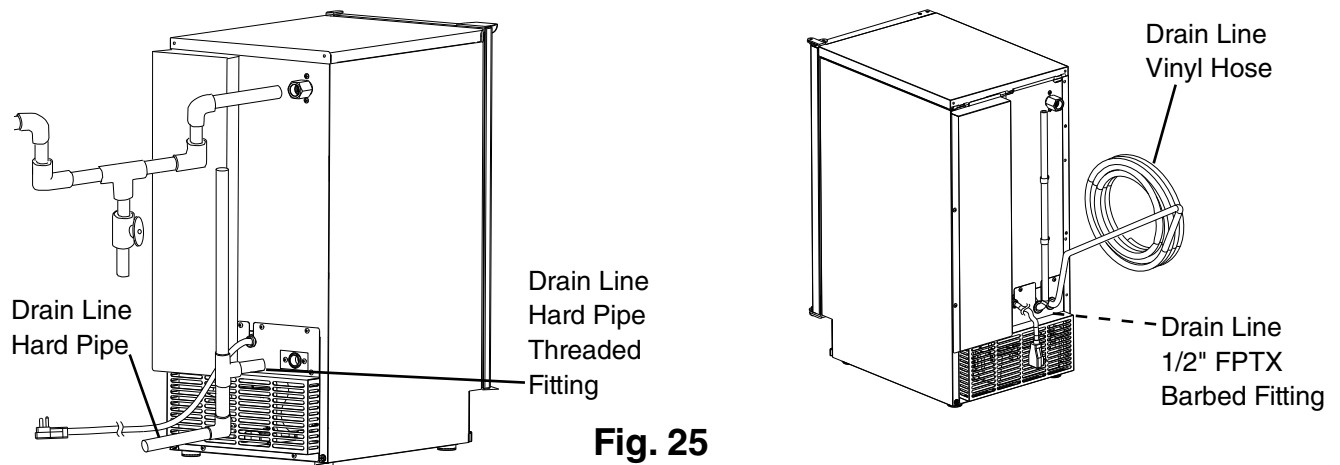

Fig. 25

c) Existing Drain Pipe Installation: When connecting to a suitable existing drain pipe (sink), the drain line must be installed in accordance with applicable national, state, and local codes and regulations. **IMPORTANT! Confirm with local and state plumbing codes before connecting to an existing drain pipe. An air gap device (not included) may be required. See Fig. 26. NOTICE! Be sure there is sufficient extra tubing for the appliance to be pulled out for service.** Do not allow traps or kinks in the hose that will restrict water flow. The maximum discharge hose length is 20 feet (6 m). The maximum discharge hose lift height is 10 feet (3.05 m). Cut excess hose as needed.

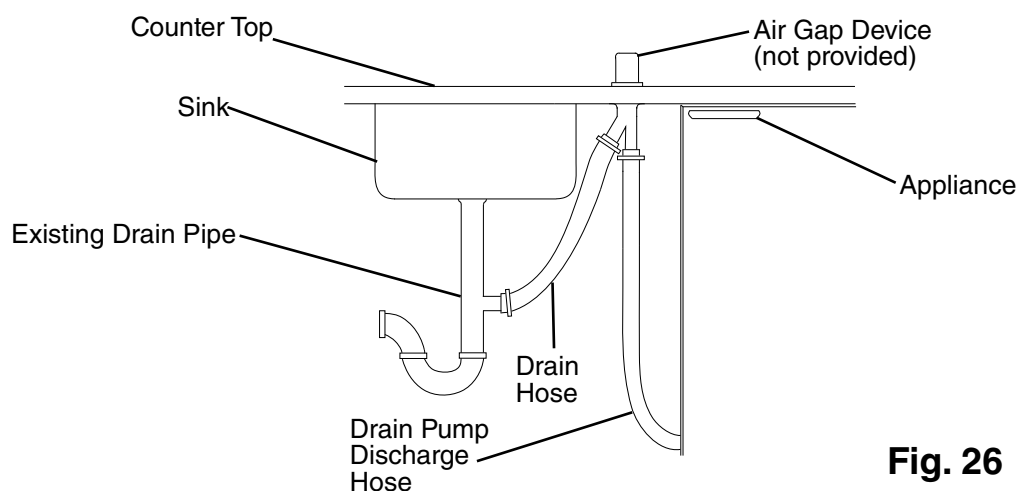

Fig. 26

G. Final Checklist

1. Pre-Startup

- 1) Is the appliance level?
- 2) Is the appliance in a site where the ambient temperature is within 45°F to 100°F (7°C to 38°C) and the water temperature within 45°F to 90°F (7°C to 32°C) all year around?
- 3) Have the shipping carton, tape, and packing material been removed from the appliance? Has the protective plastic film been removed from the panels?
- 4) Have all electrical and water connections been made? Do electrical and water connections meet all national, state, and local code and regulation requirements?
- 5) Has the power supply voltage been checked or tested against the nameplate rating? Is the power supply a properly grounded, independent 3-prong wall outlet?
- 6) Are the water supply and drain lines sized as specified? Are the water supply line shut-off valve and drain valve installed? Has the water supply pressure been checked to ensure a minimum of 10 PSIG (68.9 kPa) and a maximum of 113 PSIG (779.1 kPa)?
- 7) Is the compressor snug on all mounting pads? Have the refrigerant lines been checked to make sure they do not rub or touch other lines or surfaces? Has the fan blade been checked to make sure it turns freely?
- 8) Continue to "III.B. Startup".

2. Post-Startup

⚠ WARNING
CHOKING HAZARD: Ensure all components, fasteners, and thumbscrews are securely in place after installation. Make sure that none have fallen into the ice storage bin.

- 1) During the first 5 minutes of the freeze cycle (compressor energized), confirm bin control operation by holding ice in contact with the bin control thermistor. The appliance shuts down within 30 sec. Remove the ice. After 30 sec. the appliance restarts the automatic ice making process.
- 2) Slowly pour 24 to 30 oz. (710 to 890 ml) of water over the ice storage bin drain hole in the ice storage bin.
- 3) Confirm that the drain pump water is discharged through the drain line.
- 4) Make sure there are no water leaks.
- 5) Are all components, fasteners, and thumbscrews securely in place?
- 6) Has the end user been given the instruction manual, and instructed on how to operate the appliance and the importance of the recommended periodic maintenance?
- 7) Has the end user been given the contact information of an authorized service agent?
- 8) Has the warranty registration been completed and submitted to the factory?

III. Operating Instructions



R-290 Class A3 Flammable Refrigerant Used

⚠ DANGER

Risk of Fire or Explosion. Flammable Refrigerant Used.

- Be sure to follow all Important Safety Information located at the beginning of this manual.
- Failure to install, operate, and maintain the appliance in accordance with this manual will adversely affect safety, performance, component life, and warranty coverage and may result in costly water damage.
- Keep clear of obstruction all ventilation openings in the appliance enclosure or in the structure for building-in.

Risque D'Incendie ou D'Explosion. Fluide Frigorigène Inflammable Utilisé.

- Veuillez à respecter toutes les consignes de sécurité importantes figurant au début de ce manuel.
- Le fait de ne pas installer, utiliser et entretenir l'appareil conformément à ce manuel aura des conséquences négatives sur la sécurité, les performances, la durée de vie des composants et la couverture de la garantie, et peut entraîner des dégâts des eaux coûteux.
- Ne pas obstruer les ouvertures de ventilation dans l'enceinte de l'appareil ou dans la structure d'encastrement.

A. Important Notes About Usage

NOTICE

- Protect the floor when moving the appliance to prevent damage to the floor.
- Be aware of water left in the discharge pipe or hose in elevated drain line applications.
- To help ensure that the ice storage bin drain remains clear, follow the instructions in "IV.C. Ice Storage Bin Drain" once every 3 months or as often as necessary for conditions. If the ice storage bin drain becomes clogged, water could build up in the bin and overflow, leading to costly water damage.
- Test the drain pump operation every time the appliance is cleaned and sanitized. See "IV.D. Drain Pump" for details. If the drain pump is not operating properly, water could back up and overflow, leading to costly water damage.
- If water collects in the bin and will not drain, turn off the appliance and close the water supply line shut-off valve. Call for service.
- Do not leave the appliance on during extended periods of non-use, extended absences, or in sub-freezing temperatures. To properly prepare the appliance for these occasions, follow the instructions in "V. Preparing the Appliance for Periods of Non-Use."
- Keep ventilation openings, in the appliance enclosure or in the built-in structure, clear of obstruction.
- Do not place objects on top of the appliance.
- The ice storage bin is for ice use only. Do not store anything else in the ice storage bin.

B. Startup and Bin Control Check

⚠ WARNING

- All parts are factory-adjusted. Improper adjustments may adversely affect safety, performance, component life, and warranty coverage.
- To reduce the risk of electric shock, do not touch the power switch, control switch, or plug (on corded models) with damp hands. If you have to slide the appliance back for a built-in installation, make sure you do not damage or pinch the water supply line, drain line, or power cord.

NOTICE

- If the appliance is turned off, wait for at least 3 min. before restarting the appliance to prevent damage to the compressor.
- At startup, confirm that all internal and external connections are free of leaks.

- 1) Open the water supply line shut-off valve.
- 2) Make sure the control switch is in the "OFF" position. Plug the appliance into the electrical outlet. **WARNING! To reduce the risk of electric shock, do not touch the control switch or plug with damp hands. If you have to slide the appliance back for a built-in installation, make sure you do not damage or pinch the water supply line, drain line, or power cord.**
- 3) If required by sanitation code in your area, seal the perimeter where the appliance touches the floor with approved caulk compound in a smooth and easily cleanable manner.
- 4) Move the control switch to the "ICE" position to start the automatic icemaking process. Allow the appliance to operate for 2 minutes. This allows time for the water tank to fill.
- 5) Move the control switch to the "OFF" position.
- 6) Inside the ice storage bin, disconnect the suction tube by squeezing the tabs and pulling the tube clear. See Fig. 27. Allow the water tank to drain.
- 7) Reconnect the suction tube as illustrated. See Fig. 28. Make sure the tabs lock into place; a loose fitting may cause a water leak.
- 8) Clean the ice storage bin liner, door liner, and door gasket using a neutral cleaner. Rinse thoroughly after cleaning.

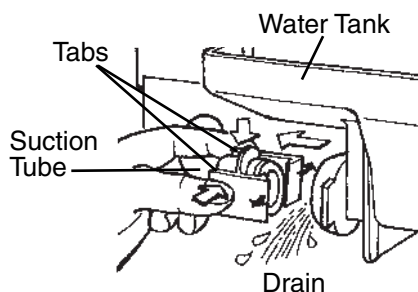

Fig. 27

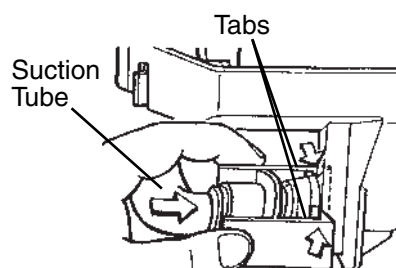

Fig. 28

- 9) Move the control switch to the "ICE" position to start the automatic icemaking process.
- 10) During the first 5 min. of the freeze cycle (compressor energized), confirm bin control operation by holding ice in contact with the bin control thermistor. See Fig. 29. The appliance shuts down within 30 sec. Remove the ice. After 30 sec. the appliance restarts the automatic ice making process.

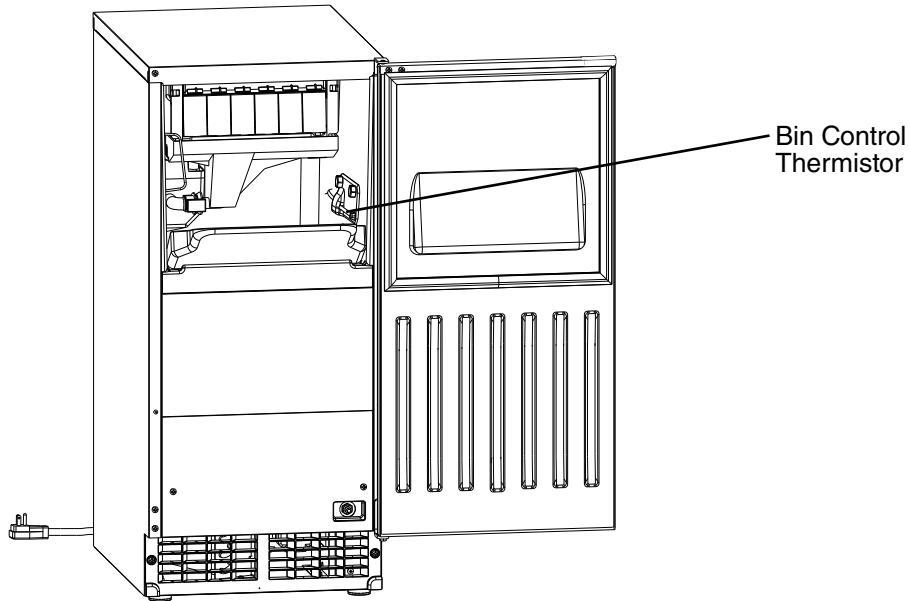

Fig. 29

- 11) Move the control switch to the "OFF" position, then unplug the appliance from the electrical outlet. **WARNING! To reduce the risk of electric shock, do not touch the control switch or plug with damp hands.**
- 12) Remove all ice from the ice storage bin.
- 13) Plug the appliance back in to the electrical outlet.
- 14) Slowly pour 24 to 30 oz. (710 to 890 ml) of water over the ice storage bin drain hole in the ice storage bin.
- 15) If water pumps out properly and the drain pump then de-energizes, proceed to step 16. If water does not pump out properly and/or the drain pump does not de-energize, the appliance must be serviced by a qualified service technician before proceeding.

- 16) Move the control switch to the "ICE" position.
- 17) Check the drain pump back-up safety switch: Pour another 24 to 30 oz. (710 to 890 ml) of water into the appliance's ice storage bin, then completely restrict/block the appliance hard pipe drain line or the appliance vinyl tubing drain line while the drain pump is operating. See Fig. 30. Pour more water into the icemaker's ice storage bin until the appliance turns off. The drain pump will continue to operate. Check for leaks.
- 18) Remove the drain line restriction and allow the water to be pumped out normally. Power to the appliance will be restored when the water in the drain pump returns to a normal level and the back-up safety switch closes.
- 19) Confirm that water is discharged through the discharge hose. The drain pump should then de-energize.
- 20) Make sure there are no water leaks.
- 21) If the appliance fails to turn off with the drain line restricted or the pump fails to pump out the water, the appliance must be serviced by a qualified service technician.
- 22) Return to "II.G.2. Post Startup."

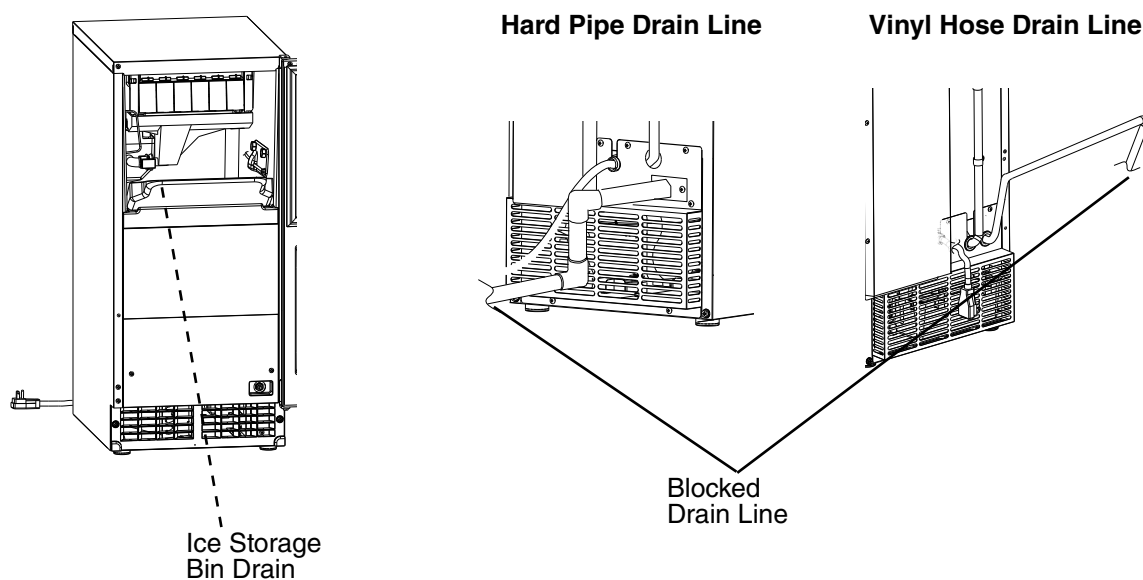

Fig. 30

IV. Maintenance

This appliance must be maintained in accordance with the instruction manual and labels provided with the appliance. Consult with your local Perlick Certified Service Representative about maintenance service. To obtain the name and phone number of your local Perlick Certified Service Representative, visit www.perlick.com.

WARNING

- Only qualified service technicians should service this appliance.
- Failure to install, operate, and maintain the appliance in accordance with this manual will adversely affect safety, performance, component life, and warranty coverage.
- Move the control switch to the "OFF" position and unplug the appliance from the electrical outlet before servicing.
- To reduce the risk of electric shock, do not touch the control switch or plug with damp hands.
- **CHOKING HAZARD:** Ensure all components, fasteners, and thumbscrews are securely in place after any maintenance is performed. Make sure that none have fallen into the ice storage bin.
- After service, make sure that there are no wires pinched between the panels and appliance. Make sure you do not damage or pinch the water supply line, drain line, or power cord.

A. Maintenance Schedule

The maintenance schedule below is a guideline. More frequent maintenance may be required depending on water quality, the icemaker's environment, and local sanitation regulations.

Maintenance Schedule		
Frequency	Area	Task
Weekly	Scoop	Clean the scoop using a neutral cleaner. Rinse thoroughly after cleaning.
Monthly	External Water Filters	Check for proper pressure and change if necessary.
	Icemaker Exterior	Wipe down with clean, soft cloth. Use a damp cloth containing a neutral cleaner to wipe off oil or dirt build up. Clean any chlorine staining (rust colored spots) using a non-abrasive cleaner like Zud or Bon Ami.
Every 3 Months	Ice Storage Bin Drain	Maintain as outlined in "IV.C. Ice Storage Bin Drain."
Yearly	Icemaker and Ice Storage Bin	Clean and sanitize per the cleaning and sanitizing instructions provided in this manual. See "IV.B. Cleaning and Sanitizing Instructions."
	Drain Pump	Test as outlined in "IV.D. Drain Pump."
	Water Supply Inlet	Close the icemaker water supply line shut-off valve and drain the water system. Clean the water supply inlet screen.
	Condenser	Inspect. Clean if necessary. See "IV.E. Condenser."
	Water Hoses	Inspect the water hoses and clean/replace if necessary.

B. Cleaning and Sanitizing Instructions

This appliance must be cleaned and sanitized at least once a year. More frequent cleaning and sanitizing may be required in some water conditions.

⚠ WARNING

- To prevent injury to individuals and damage to the appliance, do not use ammonia type cleaners.
- Carefully follow any instructions provided with the cleaning and sanitizing solutions.
- Always wear liquid-proof gloves and goggles to prevent the cleaning and sanitizing solutions from coming into contact with skin or eyes.
- After cleaning and sanitizing, be careful not to leave any solution in the appliance.

1. Cleaning Solution

Dilute 4 fl. oz. (118 ml or 8 tbs) of Nu-Calgon "Liquid Ice Machine Cleaner" with 1 gallon (3.8 l) of warm water. This is a minimum amount. Make more solution if necessary.

IMPORTANT! For safety and maximum effectiveness, use the solution immediately after dilution.

2. Cleaning Procedure

- 1) Remove all ice from the evaporator and the ice storage bin.

Note: To remove cubes on the evaporator, move the control switch to the "OFF" position and then move it back to the "ICE" position after 3 minutes. The harvest cycle starts and the cubes will be removed from the evaporator.

- 2) Move the control switch to the "OFF" position.

- 3) Inside the ice storage bin, disconnect the suction tube by squeezing the tabs and pulling the tube clear. See Fig. 31. Allow the water tank to drain.

- 4) Reconnect the suction tube as illustrated. See Fig. 32. Make sure the tabs lock into place; a loose fitting may cause a water leak.

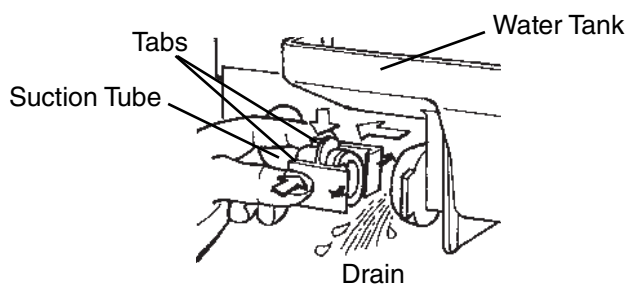

Fig. 31

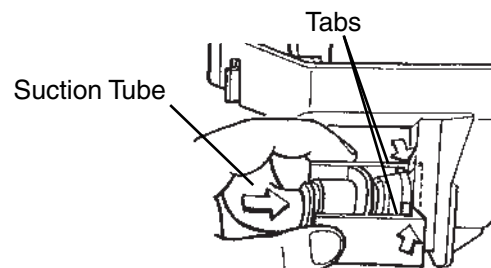

Fig. 32

- 5) Slowly pour the cleaning solution into the water tank.
- 6) Move the control switch to the "WASH" position.
- 7) Allow the cleaning solution to circulate for 30 minutes, then move the control switch to the "OFF" position.
- 8) Disconnect the suction tube. Allow the water tank to drain, then reconnect the suction tube.
- 9) Move the control switch to the "ICE" position and allow the appliance to operate for 2 minutes. This allows the water tank to fill with water.
- 10) Move the control switch to the "WASH" position.
- 11) Allow the water to circulate for 5 minutes, then move the control switch to the "OFF" position.
- 12) Disconnect the suction tube. Allow the water tank to drain, then reconnect the suction tube.
- 13) Repeat steps 9 through 12 three more times to rinse thoroughly.

3. Sanitizing Solution

Dilute 0.34 fl. oz. (10.1 ml or 0.68 tbs) of a 7.5% sodium hypochlorite solution (chlorine bleach) with 1 gallon (3.8 l) of warm water. This is a minimum amount. Make more solution if necessary. Using a chlorine test strip or other method, confirm that you have a concentration of about 200 ppm. **IMPORTANT! For safety and maximum effectiveness, use the solution immediately after dilution.**

4. Sanitizing Procedure

- 1) Make sure the control switch is in the "OFF" position and the ice storage bin is empty.
- 2) Remove the slope from the ice storage bin by carefully bending it in the center and releasing it from the 2 slope shafts. See Fig. 33.
- 3) Remove each separator by lifting it to the horizontal position and pushing it hard inward. See Fig. 34.

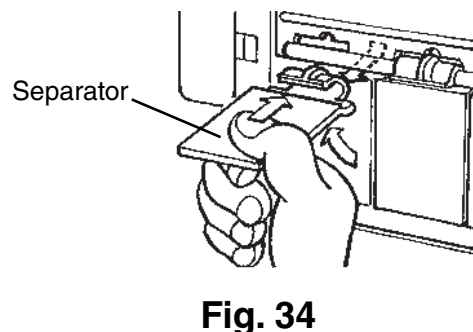
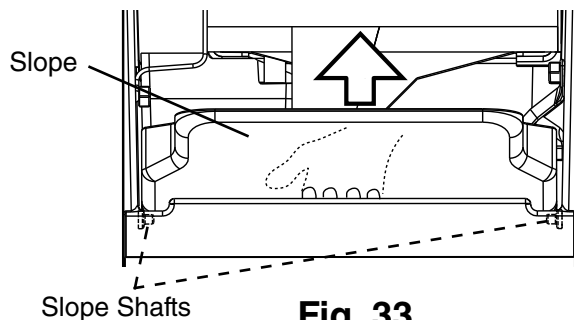

- 4) Disconnect the suction tube. Allow the water tank to drain.
- 5) Spread out the tabs to unlock the water tank, then slide it out. See Fig. 35.
- 6) Lift the ice chute up from the left and right brackets. See Fig. 36.

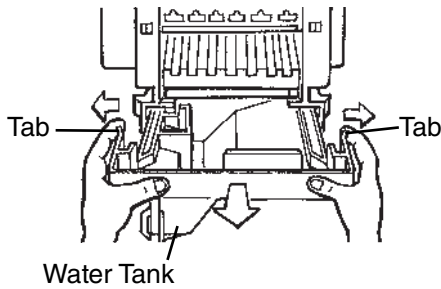

Fig. 35

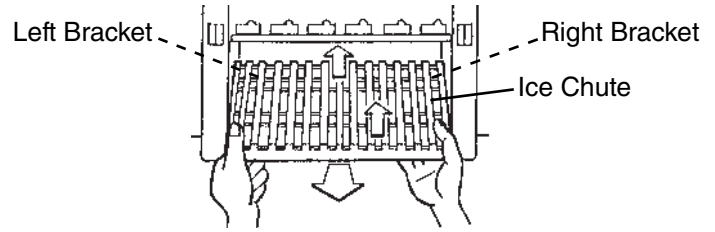

Fig. 36

- 7) Disconnect the discharge tube from the spray assembly, then slide out the spray assembly. See Fig. 37.
- 8) Remove the two caps. See Fig. 38.

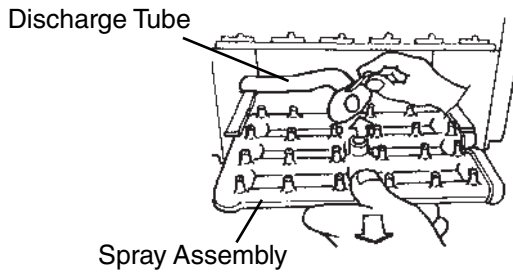

Fig. 37

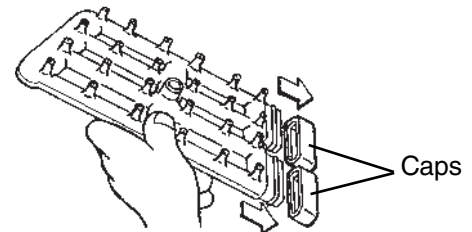

Fig. 38

- 9) Soak all of the removed parts and the scoop in the sanitizing solution for 10 minutes. If the spray assembly nozzles are clogged, clean them with a wire or a suitable brush.
- 10) Rinse the parts thoroughly with clean water.
- 11) Refit the 2 caps in their correct positions. Make sure the reducing pipe is in place in the center. See Fig. 39.
- 12) Slide in the spray assembly along the rails on the left and right brackets. See Fig. 40. Connect the discharge tube securely to the spray assembly; a loose fitting may cause a water leak.

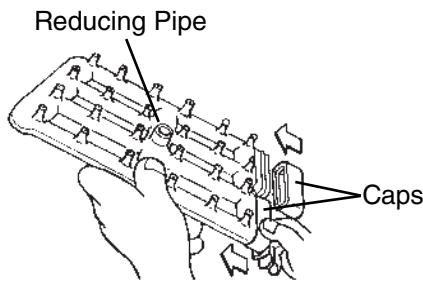

Fig. 39

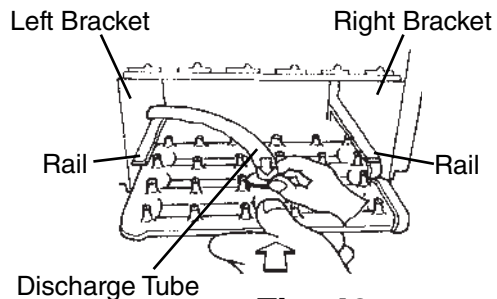
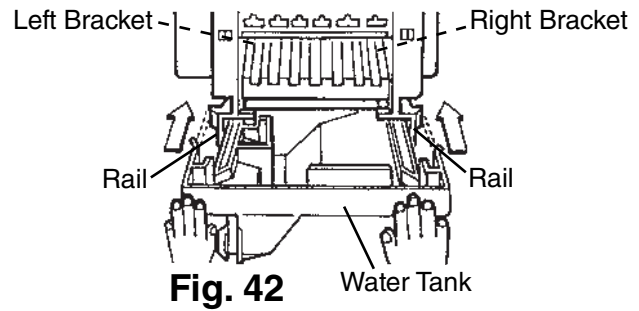
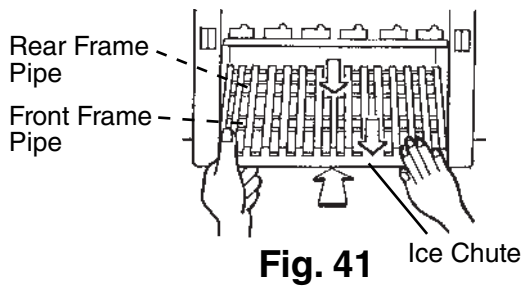

Fig. 40

13) Position and lock the ice chute onto the left and right brackets by pushing the ice chute down until it clicks onto both brackets. See Fig. 41.

14) Slide in the water tank along the rails at the bottom of the left and right brackets until it locks into place. See Fig. 42.



15) Reconnect the suction tube.

16) Hook each separator onto the rail, then pull it hard towards you until it locks into place. See Fig. 43.

17) Replace the slope in its correct position. See Fig. 44.

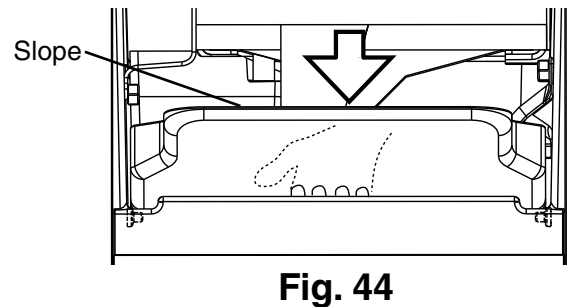
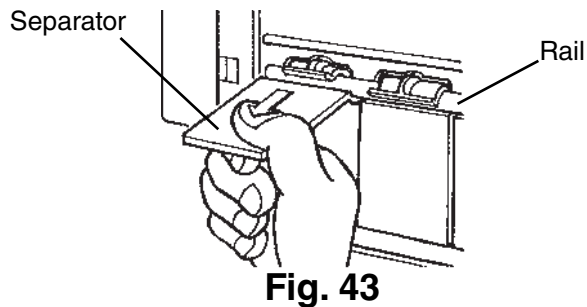

18) Discard the sanitizing solution.

19) Mix a new batch of the sanitizing solution and slowly pour it into the water tank.

20) Move the control switch to the "WASH" position.

21) After circulating the sanitizing solution for 15 minutes, move the control switch to the "OFF" position.

22) Disconnect the suction tube. Allow the water tank to drain, then reconnect the suction tube.

23) Repeat steps 19 through 22 one time.

24) Move the control switch to the "ICE" position and allow the appliance to operate for 2 minutes. This allows the water tank to fill with water.

25) Move the control switch to the "WASH" position.

26) Allow the water to circulate for 5 minutes, then move the control switch to the "OFF" position.

27) Disconnect the suction tube. Allow the water tank to drain, then reconnect the suction tube.

28) Repeat steps 24 through 27 two more times to rinse thoroughly.

29) Clean the ice storage bin liner, door liner, and door gasket with a neutral cleaner. Rinse thoroughly after cleaning.

30) Move the control switch to the "ICE" position to start the automatic icemaking process.

C. Ice Storage Bin Drain

In some conditions, slime may build up inside the ice storage bin drain and prevent water from draining properly. To prevent this buildup, perform the following procedure once every 3 months or as often as necessary for conditions.

NOTICE

If the ice storage bin drain becomes clogged, water could build up in the bin and overflow, leading to costly water damage.

- 1) Move the control switch to the "OFF" position. **WARNING! To reduce the risk of electric shock, do not touch the control switch with damp hands.**
- 2) Remove all ice from the ice storage bin.
- 3) Mix a batch of sanitizing solution by diluting 0.34 fl. oz. (10.1 ml or 0.68 tbs) of a 7.5% sodium hypochlorite solution (chlorine bleach) with 1 gallon (3.8 l) of warm water. Using a chlorine test strip or other method, confirm that you have a concentration of about 200 ppm.
- 4) Slowly pour the sanitizing solution into the ice storage bin.
- 5) After all of the solution has drained (pumped out), clean the ice storage bin liner with a neutral cleaner. Rinse thoroughly with clean water.
- 6) Move the control switch to the "ICE" position to start the automatic icemaking process.

D. Drain Pump

NOTICE

Be aware of water left in the discharge pipe or hose in elevated drain line applications.

- 1) To test the operation of the drain pump and internal safety switch, move the control switch to the "ICE" position or the power switch to the "ON" position (dependent on model).
- 2) Pour 24 to 30 oz. (710 to 890 ml) of water into the appliance's ice storage bin, then completely restrict the discharge hose while the drain pump is operating. Pour more water into the appliance's ice storage bin until the appliance turns off. The drain pump will continue to operate.
- 3) Check for leaks. Remove the discharge hose restriction and allow the water to be pumped out normally. The power to the appliance will be restored when the water in the drain pump returns to a normal level.

E. Condenser

Check the condenser once a year, and clean if required by following the steps below. More frequent cleaning may be required depending on location.

⚠ WARNING

- Move the control switch to the "OFF" position and unplug the icemaker from the electrical outlet before cleaning the condenser.
- To reduce the risk of electric shock, do not touch the control switch or plug with damp hands.
- Condenser fins are sharp. Use care when cleaning.

- 1) Move the control switch to the "OFF" position and unplug the appliance from the electrical outlet. **WARNING! To reduce the risk of electric shock, do not touch the control switch or plug with damp hands.**
- 2) Remove the 2 screws securing the front panel, then remove the panel. See Fig. 45.
- 3) Remove the 2 screws securing the louver, then remove the louver.

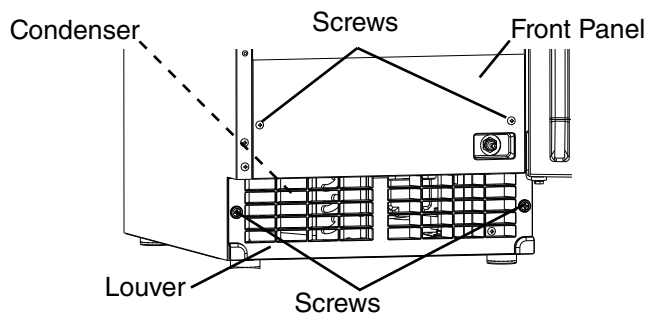

Fig. 45

- 4) Use a brush attachment on a vacuum cleaner to gently clean the condenser fins. Do not use too much force, otherwise the fins could be damaged.
- 5) Replace the louver and front panel in their correct positions. Ensure that the screws are securely in place.
- 6) Plug the appliance back in. Move the control switch to the "ICE" position to start the automatic icemaking process.

V. Preparing the Appliance for Periods of Non-Use

⚠ WARNING

Only qualified service technicians should service this icemaker.
--

NOTICE

- | |
|---|
| <ul style="list-style-type: none">• During extended periods of non-use, extended absences, or in sub-freezing temperatures, follow the instructions below to reduce the risk of costly water damage.• When the appliance is not used for two or three days under normal conditions, it is sufficient to move the control switch to the "OFF" position. |
|---|

- 1) Close the water supply line shut-off valve, then open the water supply line drain valve. See Fig. 24.
- 2) Allow the line to drain by gravity.
- 3) Attach a compressed air or carbon dioxide supply to the water supply line drain.
- 4) Move the control switch to the "ICE" position.
- 5) Blow the water supply line out using the compressed air or carbon dioxide supply.
- 6) Close the water supply line drain valve.
- 7) Move the control switch to the "OFF" position.
- 8) Unplug the appliance from the electrical outlet.
- 9) Remove all ice from the ice storage bin. Clean the ice storage bin liner using a neutral cleaner. Rinse thoroughly after cleaning.

VI. Decommissioning and Disposal



R-290 Class A3 Flammable Refrigerant Used

⚠ DANGER

Risk of Fire or Explosion. Flammable Refrigerant Used.

- Only qualified service technicians should install and service the appliance.
- Follow handling instructions carefully in compliance with national regulations.
- Dispose of properly in accordance with federal or local regulations.
- Do not puncture refrigerant tubing. Risk of fire or explosion due to puncture of refrigerant tubing; follow handling instructions carefully.
- Be sure to follow the full Decommissioning and Disposal information located in the Service Manual for this model. The Service Manual is available at www.perlick.com.

Risque D'Incendie ou D'Explosion. Fluide Frigorigène Inflammable Utilisé.

- Seuls des techniciens de service qualifiés doivent installer et entretenir l'appareil.
- Suivre attentivement les instructions de manutention conformément aux règlements nationaux.
- Mettre au rebut conformément aux conformément aux règlements fédéraux ou locaux.
- Ne pas perforer la conduite de fluide frigorigène. Risque d'incendie ou d'explosion en cas de perforation d'une canalisation de fluide frigorigène; suivez attentivement les instructions de manutention.
- Veiller à respecter l'ensemble des informations relatives à la mise hors service et à la mise au rebut figurant dans le manuel d'entretien de ce modèle. Le manuel d'entretien est disponible à l'adresse suivante: www.perlick.com.



© 2025 Perlick Corporation

8300 West Good Hope Road, Milwaukee, WI 53223, USA
perlick.com • (800) 558-5592

Form No. Z2517
Rev. 04.30.25

1A7987-010