

# RIMS-Rocket™



## Assembly, Operation, & Maintenance

Congratulations on your purchase, and thank you for selecting the RIMS-Rocket™ electric recirculation heater from Blichmann Engineering™. We are confident that it will provide you years of service and many gallons of outstanding beer. This manual will familiarize you with the assembly, operation, and maintenance of the RIMS-Rocket™ electric recirculation heater.



## IMPORTANT INFORMATION

**PLEASE READ AND THOROUGHLY UNDERSTAND THIS MANUAL PRIOR TO USE FOR IMPORTANT SAFETY INFORMATION!**

- WARNING:** Sections labeled “Warning” can lead to serious injury or death if not followed. Please thoroughly read these sections and understand them completely before use. If you do not understand them or have any questions, contact your retailer or Blichmann Engineering ([www.BlichmannEngineering.com](http://www.BlichmannEngineering.com)) before use.
- CAUTION:** Sections labeled “Caution” can lead to equipment damage or unsatisfactory performance of the equipment. Please read these sections thoroughly. If you have any questions, contact your retailer or Blichmann Engineering ([www.BlichmannEngineering.com](http://www.BlichmannEngineering.com)) before use.
- IMPORTANT:** Sections labeled “Important” should specifically be followed to ensure satisfactory results with the product.

## What’s In the Box?

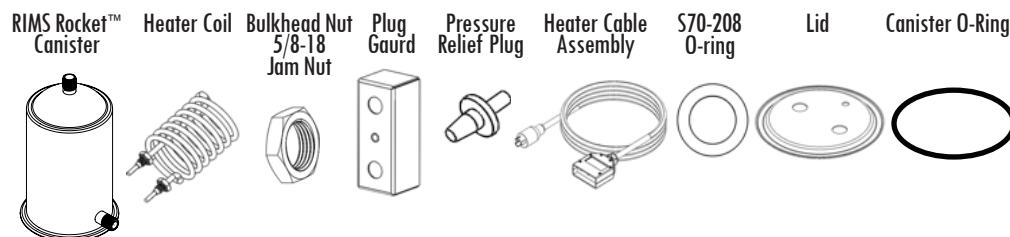

### Required Tools



**CAUTION:** Do **NOT** use any cleaner or sanitizer containing chlorine such as bleach. Over time, this will pit and erode stainless steel.

## ASSEMBLY

The RIMS-Rocket™ electric recirculation heater is packaged assembled to reduce damage in shipment. A list of components included with your RIMS-Rocket™ electric recirculation heater follows as well as the basic tools required for assembly. Please carefully review the lists below to ensure you received all of the correct parts and have the required tools prior to assembly.

It is advised to thoroughly clean the RIMS-Rocket™ electric recirculation heater prior to the first use to remove any residues from the manufacturing process. Follow the reverse of the assembly procedure to disassemble the RIMS-Rocket™ electric recirculation heater for cleaning and maintenance. It is not necessary or recommended to soak the band clamp or t-handle. Over time this will wear at the threads.

### STEP ONE:

First remove both bulkhead nuts from the heater coil. Next install the heater coil through the lid and plug guard as shown in **Figure 1**. Make certain the lid is oriented as shown or the RIMS-Rocket™ electric recirculation heater will not seal. Last, re-install the bulkhead nuts finger tight.

**WARNING:** NEVER install the RIMS-Rocket™ electric recirculation heater without the plug guard. Doing so can result in personal property damage, injury, electrocution or death.

### STEP TWO:

Using a 1" open end or adjustable wrench, hold the bulkhead fitting while tightening the bulkhead retaining nut with a 7/8" deep well socket and ratchet as shown in **Figure 2**. Tighten both bulkhead retaining nuts before proceeding.

### STEP THREE:

Place the large black O-ring over the heater coil and locate it in the recessed portion of the lid. Install the canister over the heater coil and situate it on the lid and large black O-ring seal as shown in **Figure 3**. Lastly, install the band clamp and T-handle nut.

**CAUTION:** ALWAYS apply a lubricant such as petroleum jelly, food grade silicone grease, or mineral oil to the draw bolt and T-handle nut to prevent the threads from seizing. Thread galling is not covered under warranty.

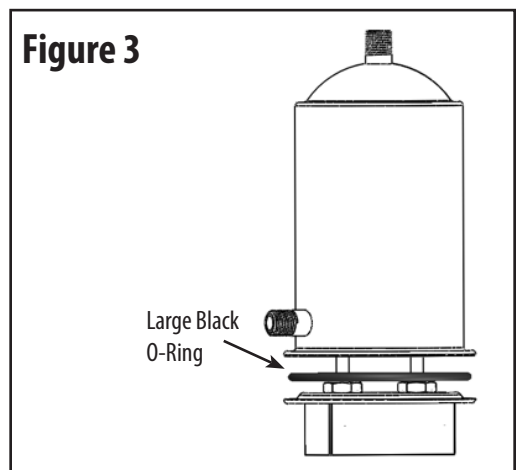
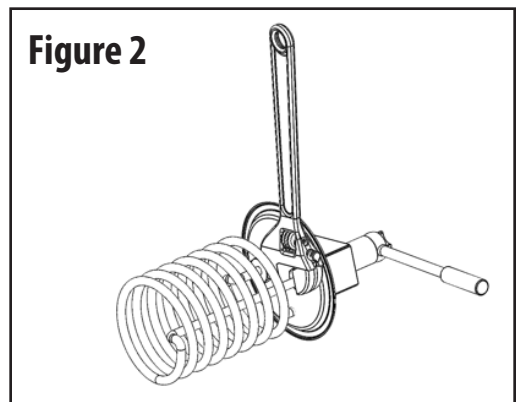
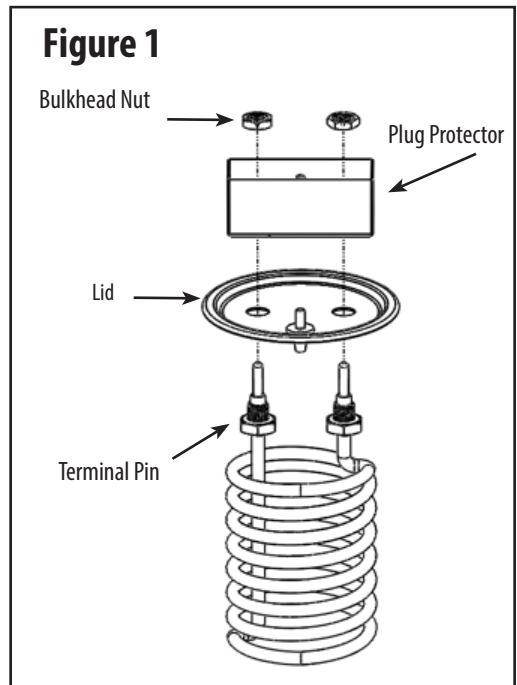

## OPERATION

**WARNING:** The RIMS-Rocket™ electric recirculation heater is only to be used in conjunction with a Ground Fault Circuit Interrupter (GFCI) protected power source. If you are uncertain about the status of your power source contact a licensed and qualified electrician familiar with National Electric Code standards before proceeding. Operating the RIMS-Rocket™ electric recirculation heater in any fashion other than described in this manual can result in personal property damage, injury, electrocution or death.

### Temperature and Power Control

The RIMS-Rocket™ electric recirculation heater requires the use of a temperature control device capable of regulating power and de-energizing the heater coil to safely operate. The RIMS-Rocket™ electric recirculation heater was designed specifically for use with the Blichmann Engineering™ BrewCommander™ electric temperature control module. Although the RIMS-Rocket™ may be compatible with other commercially available brewing controllers, the BrewCommander™ electric temperature control module provides the ultimate in safety, convenience, accuracy, and precision.

To operate the RIMS-Rocket™ electric recirculation heater, you must verify your system can maintain a minimum flow rate of  $\frac{3}{4}$  of a gallon per minute. If you are unable to achieve the minimum flow rate, the power of the heater coil must be reduced. It is highly advisable that your chosen controller is capable of controlling the power output to the heater as well as controlling system temperature. In the event of low system flow rate, the power output to the heater must be reduced to prevent scorching. The RIMS-Rocket™ electric recirculation heater is specifically designed for use with the BrewCommander™ electric temperature control module which provides the perfect means of controlling temperature and power.

### ALWAYS

- **ALWAYS** use heater with rated voltage.
- **ALWAYS** unplug heater when de-energized.
- **ALWAYS** use on level and stable hard surfaces.
- **ALWAYS** connect to a GFCI circuit.
- **ALWAYS** check power cables and connectors for signs of damage or wear prior to each use.
- **ALWAYS** check that all fasteners are properly tightened prior to each use.
- **ALWAYS** use approved control device between heater and GFCI power source.
- **ALWAYS** use genuine Blichmann Engineering™ replacement parts.
- **ALWAYS** unplug before moving.
- **ALWAYS** allow the brewing equipment to fully cool before handling.
- **ALWAYS** wear appropriate personal protective equipment, such as gloves, clothing and footwear to prevent burns and scalds.
- **ALWAYS** orient the RIMS-Rocket™ electric recirculation heater vertically with the outlet of the HopRocket™ canister up.

### NEVER

- **NEVER** leave this equipment unattended.
- **NEVER** allow children near this equipment.
- **NEVER** heat cooking oil with this equipment.
- **NEVER** operate on soft, uneven surfaces like dirt, gravel, or asphalt.
- **NEVER** use near or with combustible chemicals, gasoline, or other flammable vapors or liquids.
- **NEVER** bypass the GFCI circuit protection.
- **NEVER** operate any equipment with frayed or damaged power cables.
- **NEVER** expose electrical connections to moisture.
- **NEVER** connect heater cable assembly directly to power source.
- **NEVER** modify or alter the supplied electrical cables or connectors.
- **NEVER** operate heater with higher than rated voltage.
- **NEVER** unplug heater when energized.
- **NEVER** energize the heater without the heating coils fully submerged.
- **NEVER** immerse the terminal pins in water or cleaning solutions.

## Installation

The RIMS-Rocket™ electric recirculation heater requires a constant flow of wort, provided by a pump, to increase and maintain the temperature of your mash. To ensure the pump operates properly and the RIMS Rocket™ stays full at all times, it is critical that the **RIMS-Rocket™ is located after the outlet of the pump** and no higher than the bottom of the mash tun. A pictorial diagram with bold arrows indicating the direction of flow is shown in **Figure 4**.

**CAUTION:** Always orient the RIMS-Rocket™ electric recirculation heater vertically with the outlet of the HopRocket™ canister up.

## Temperature Sensor

The location of the temperature sensor for the temperature control module must be located as near to the outlet of the RIMS-Rocket™ as possible. Reducing the distance between the heat source and the temperature sensor minimizes overshooting the set point of the temperature control device. Although the heater may cycle on and off frequently, the stability of the system is optimized. The recommended temperature sensor location method is shown in **Figure 5**

Users of the full-sized

## Pressure Relief Plug

**WARNING:** When using the RIMS-Rocket™ electric recirculation heater, always have the outlet of the HopRocket™ canister unrestricted. NEVER install valves, fittings or any other devices downstream from the outlet of the HopRocket™ canister which can impede or block the flow of liquid or evacuation of pressure from the HopRocket™ canister.

Your RIMS-Rocket™ electric recirculation heater comes from the factory with a pressure relief device installed to prevent unsafe over pressurization of the canister. When installing the RIMS-Rocket™ electric recirculation heater, always make sure the pressure relief device is installed as shown in the sectioned diagram in **FIGURE 6**. Also, make certain that the bottom of the HopRocket™ canister is oriented in a safe direction in the event of over pressurization. Do not stand or allow children or pets in the area directly below the RIMS-Rocket™ electric recirculation heater and HopRocket™ canister.

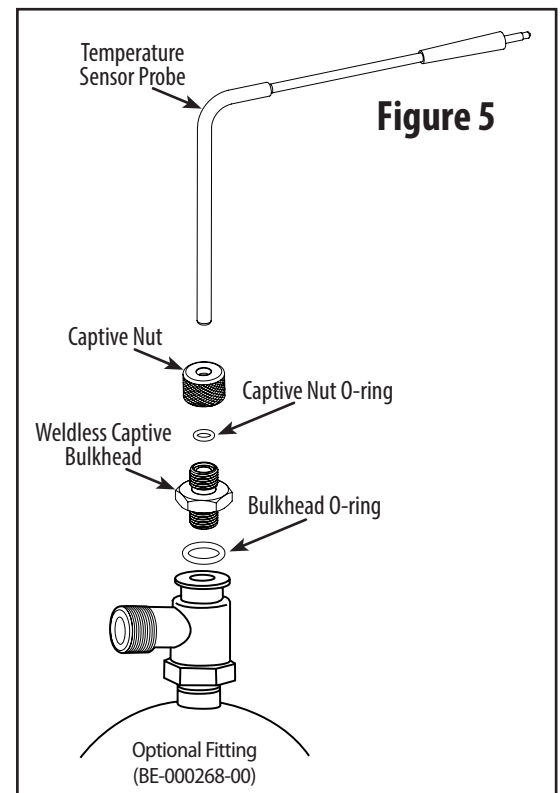
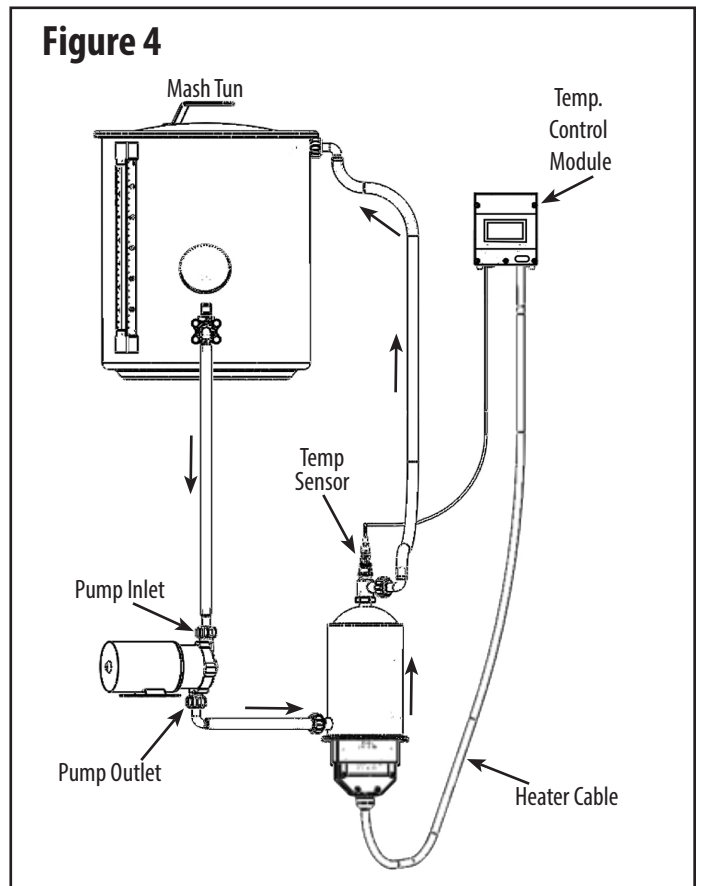

**ALWAYS** orient the pressure relief device as shown in **Figure 6**. Make sure the flange of the silicone pressure relief plug is located on the same side of the lid as the plug protector

**WARNING:** NEVER replace the pressure relief device with anything other than genuine Blichmann Engineering™ replacement parts. The use of non-OEM parts can result in dangerous conditions that can result in personal property damage, injury, electrocution or death.

**WARNING:** NEVER energize the heater without the heating coils fully submerged. “Dry firing” the RIMS-Rocket™ electric recirculation heater will cause the heater coil to reach excessive temperatures which can create a dangerous situation which can result in personal property damage, injury, electrocution or death.

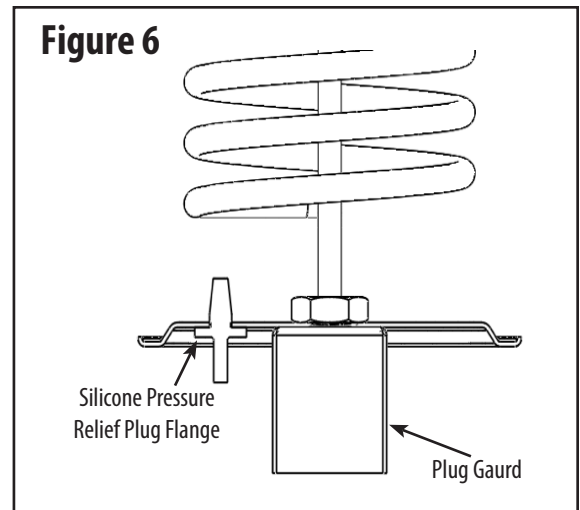

## Connecting the Heater

First verify the power control device is turned off and disconnected from any power source. Next connect the custom molded plug to the terminal pins of the RIMS-Rocket™ as shown in **Figure 7**. After the custom molded plug is connected to the heater, connect the male twist lock connector to the power control device. At this point is safe to connect the power control device to a GFCI protected power source.

**TIP:** To help relieve cable strain and provide more convenient cable routing, the heater cord can be installed on the custom molded plug in the alternate position by removing the six screws from the plug body and relocating the cable strain relief fitting to the alternate position.

**WARNING:** The internal orientation of the brass connectors must be maintained. Contact a licensed and qualified electrician for assistance if you are uncertain with reorienting the cable strain relief fitting.

**WARNING:** NEVER operate the RIMS-Rocket™ electric recirculation heater without the plug protector installed!

**WARNING:** NEVER plug the RIMS-Rocket™ electric recirculation heater directly into a power source. ALWAYS use a power control device capable of de-energizing the heater coil.

**WARNING:** NEVER plug in or unplug the heater cord from the heater coil when energized. Doing so will result in arc damage to electrical connections.

**CAUTION:** Before making any electrical connections to the RIMS-Rocket™ electric recirculation heater, make certain that the RIMS-Rocket™ is completely filled with water or wort and your system is able to maintain a minimum flow rate of  $\frac{3}{4}$  of a gallon per minute. If your system cannot achieve the minimum flow rate, the average power output of the RIMS-Rocket™ electric recirculation heater must be reduced.

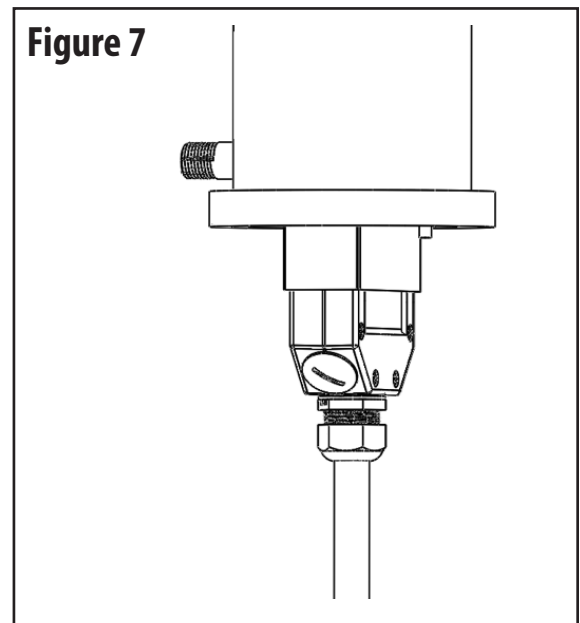

## Heating

Before energizing the RIMS-Rocket™ electric recirculation heater, you must verify your system can maintain a minimum flow rate of ¾ of a gallon per minute. If you are unable to achieve the minimum flow rate, the power of the heater coil must be reduced. The RIMS-Rocket™ electric recirculation heater is specifically designed for use with the BrewCommander™ electric temperature control module which provides the perfect means of controlling temperature and power.

**IMPORTANT:** The ability to maintain required flow rates and modulate power is necessary to prevent scorching.

**WARNING:** The outlet of the RIMS-Rocket™ electric recirculation heater must always be unobstructed and open to atmospheric pressure. NEVER close both the inlet and outlet of the RIMS-Rocket™ electric recirculation heater. Doing so can result in extremely dangerous pressures that can cause personal property damage, injury, electrocution or death.

**WARNING:** When operating the RIMS-Rocket™ electric recirculation heater, the surface of the heater and surrounding areas will be hot and can cause burns. Always keep children and pets away from hot surfaces and wear appropriate personal protective equipment such as gloves, clothing and footwear to prevent burns and scalds.

## MAINTENANCE:

### Cleaning

The RIMS-Rocket™ electric recirculation heater will require cleaning after use. First confirm the custom molded plug is disconnected from the RIMS-Rocket™ electric recirculation heater and is disconnected from any power source. Use hot water and Five Star Chemical's Powdered Brewery Wash or similar detergent with a scrub brush or ScotchBrite™ scouring pad to remove any heavy soil deposits. Periodically remove the RIMS-Rocket™ electric recirculation heater from the lid to remove build-up of mineral deposits. If you brew with particularly hard water, you may need to use a weak acid, such as distilled white vinegar, to assist with removing mineral deposits. The terminal pins of the RIMS-Rocket™ electric immersion heater can tolerate incidental contact with water in the course of cleaning, however, never immerse or soak the terminal pins of the RIMS-Rocket™ in water or cleaning solutions.

Before and after each use, inspect the RIMS-Rocket™ electric recirculation heater, custom molded plug, cable, and connectors for wear or damage. If any of the above parts show signs of wear or damage, discontinue use and contact your Blichmann Engineering™ authorized retailer for replacement parts.

**WARNING:** ALWAYS make sure the RIMS-Rocket™ electric recirculation heater is disconnected from all power sources before cleaning.

**WARNING:** NEVER immerse or soak the terminal pins of the RIMS-Rocket™ in water or cleaning solutions. Doing so can cause permanent damage to the heater and create an unsafe condition which can result in personal property damage, injury, electrocution or death. ALWAYS allow the RIMS-Rocket™ electric recirculation heater to thoroughly dry after cleaning and before reinstalling.

**CAUTION:** Never use chlorine bleach or H-Cl acid to clean your RIMS-Rocket™ electric recirculation heater. Pitting in the surface of the heater coil and/or bulk-head fittings caused by the use of products containing chlorine or H-Cl acid is not covered under the warranty.

ITEM NUMBER	DESCRIPTION	PART NUMBER	QUANTITY
1	RIMS-Rocket Canister	HR-001-09	1
2a	Heater Coil - 240V	HTR-100-01	1
2b	Heater Coil - 120V	HTR-120-01	1
3	O-Ring	BE-000373-00	2
4	Canister O-Ring	HR-005-02	
5	Lid	HTR-201-00	1
6	Pressure Relief Plug	BE-000444-00	1
7	Plug Protector	HTR-101-01	1
8	Bulkhead Retainer Nut	BE-000448-00	2
9a	Heater Cable Assembly - 120V	BE-000404-00	1
9b	Heater Cable Assembly - 240V	BE-000405-00	1

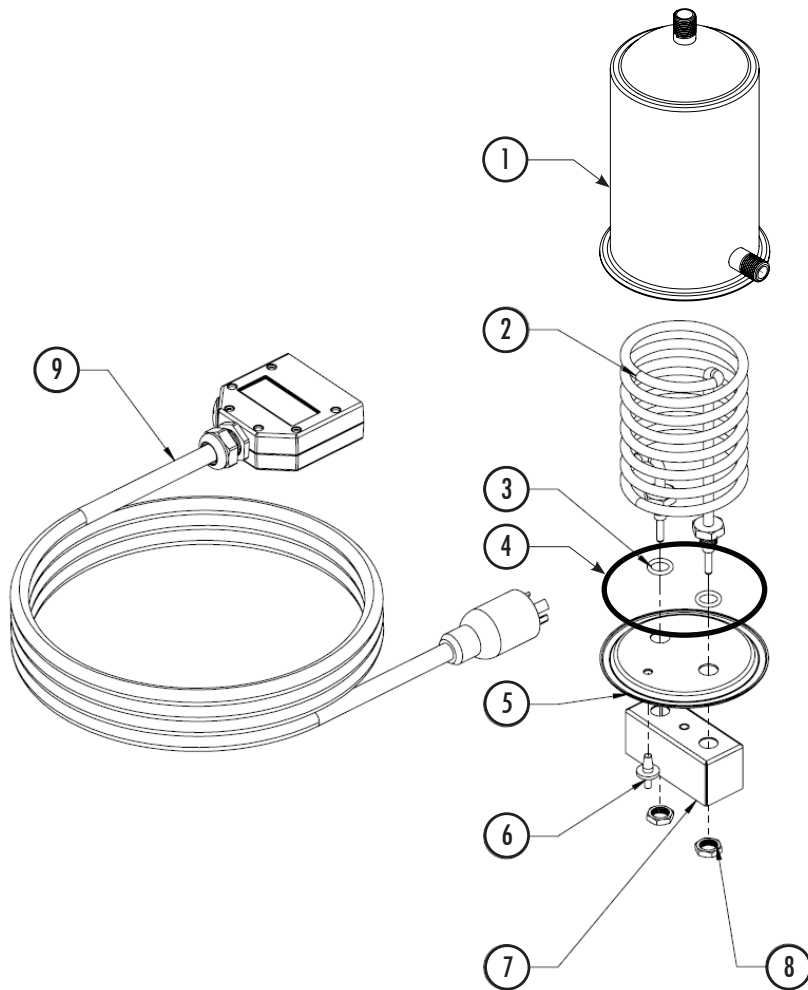

# Blichmann Engineering Product Warranty

## A. Limited Warranty

1. Blichmann Engineering warrants to the original purchaser that this product will be free from manufacturing defects in material and workmanship for a period of one (1) year from the date of purchase by the customer. Proof of purchase is required. Blichmann Engineering's obligation to repair or replace defective materials or workmanship is the sole obligation of Blichmann Engineering under this limited warranty.
2. This product is for home use only. The limited warranty covers only those defects that arise as a result of normal use of the product and does not cover any other problems, including, but not limited to, those that arise as a result of:
  - a. Improper maintenance or modification;
  - b. Damage due to incorrect voltage or improper wiring by customer;
  - c. Operation outside of the product's specifications;
  - d. Carelessness or neglect to operate the product in accordance with instructions provided with the product;
  - e. Damaging the tamper label on the product;
  - f. Damage by over-tightening the fasteners;
  - g. Failure to follow cleaning and / or maintenance procedures; or
  - h. Exceeding published operational temperatures.
3. Blichmann Engineering reserves the right to request delivery of the defective component for inspection before processing the warranty claim. If Blichmann Engineering receives, during the applicable warranty period, notice of a defect in any component that is covered by the warranty, Blichmann Engineering shall either repair or replace the defective component with a new or rebuilt component at Blichmann Engineering's option.
4. Blichmann Engineering must be notified within seven (7) days of the delivery date of any shipping damage. Customer is responsible for shipping damage outside of this time period. Approval for return must be provided by Blichmann Engineering prior to any return. Customer is responsible for keeping all original packaging material for warranty returns. Blichmann Engineering is not responsible for damage from improperly packaged warranty returns, and these repair costs will be the sole responsibility of the customer. Shipping costs for warrantee returns are covered only for the contiguous United States.
5. Blichmann Engineering's limited warranty is valid in any country where the product is distributed.

## B. Limitations of Warranty

1. Any implied warranty that is found to arise by way of state or federal law, including any implied warranty of merchantability or any implied warranty of fitness, is limited in duration to the terms of this limited warranty and is limited in scope of coverage to this warranty. Blichmann Engineering disclaims any express or implied warranty, including any implied warranty of fitness for a particular purpose or merchantability, on items excluded from coverage as set forth in this limited warranty.
2. Blichmann Engineering makes no warranty of any nature beyond that contained in this limited warranty. No one has authority to enlarge, amend, or modify this limited warranty, and Blichmann Engineering does not authorize anyone to create any other obligation for it regarding this product.
3. Blichmann Engineering is not responsible for any representation, promise, or warranty made by any independent dealer or other person beyond what is expressly stated in this limited warranty. Any selling or servicing dealer is not Blichmann Engineering's agent, but an independent entity.

## C. Limitations of Liability

1. The remedies provided in this warranty are the customer's sole and exclusive remedies.
2. Except for the obligations specifically set forth in this warranty, in no event shall Blichmann Engineering be liable for direct, indirect, special, incidental, or consequential damages, whether based on contract, tort, or any other legal theory and whether or not advised of the possibility of such damages.
3. This warranty does not cover, and in no event shall Blichmann Engineering be liable for, travel, lodging, or any other expense incurred due to manufacturing defects in material and workmanship, or any other reason.
4. Any performance of repairs after the warranty coverage period has expired or performance of repairs regarding anything excluded from coverage after this limited warranty shall be considered good-will repairs and they will not alter the terms of this limited warranty, or extend any warranty coverage period.
5. Venue for any legal proceedings relating to or arising out of this warranty shall be in Tippecanoe County, Indiana, United States, which courts will have exclusive jurisdiction.

## D. Local Law

1. This warranty gives the customer specific legal rights. The customer may also have other rights that vary from state to state in the United States or other countries.
2. To the extent that this warranty is inconsistent with local law, it shall be deemed modified, only to the extent necessary to be consistent with such local law.

This product uses food grade materials anywhere the product touches the beverage.

Warning: This product contains or may contain chemical(s) known to the State of California to cause cancer, birth defects, or other reproductive harm.